

# SEMI-HERMETIC RECIPROCATING

Compressors for refrigeration & air conditioning

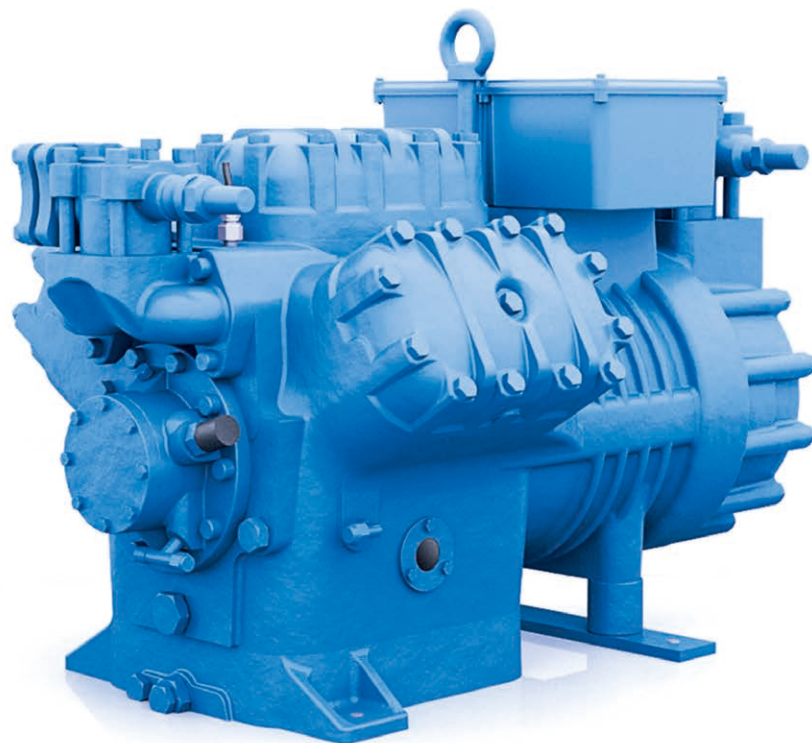

50Hz & 60Hz

FCAT\_100\_24\_00\_EN  
April 2024

LEGAL DISCLAIMER: While Frascold has made every effort at the time of publication to ensure the accuracy of the information provided herein, product specifications and performances could be subject to change without notice. You can find the most updated information in our Product Selection Software FSS3 at the link: <https://www.frascold.it/en/software>

Semi-hermetic reciprocating compressors

# INDEX

---

4	About the Company
5	Segments and Solutions
6	Product Information
18	Technical Data and Operating Limits
26	Technical Drawings and Dimensions
40	Contact us

# ABOUT THE COMPANY

Frascold manufactures over 70,000 screw and reciprocating compressors a year. Our 53,000 m<sup>2</sup> factory outside of Milan (Italy) houses our advanced engineering, manufacturing and testing facilities. More than 200 employees work in the Headquarters and in the Subsidiaries based in the United States, China and India, with distribution partners and service centers in 86 countries.

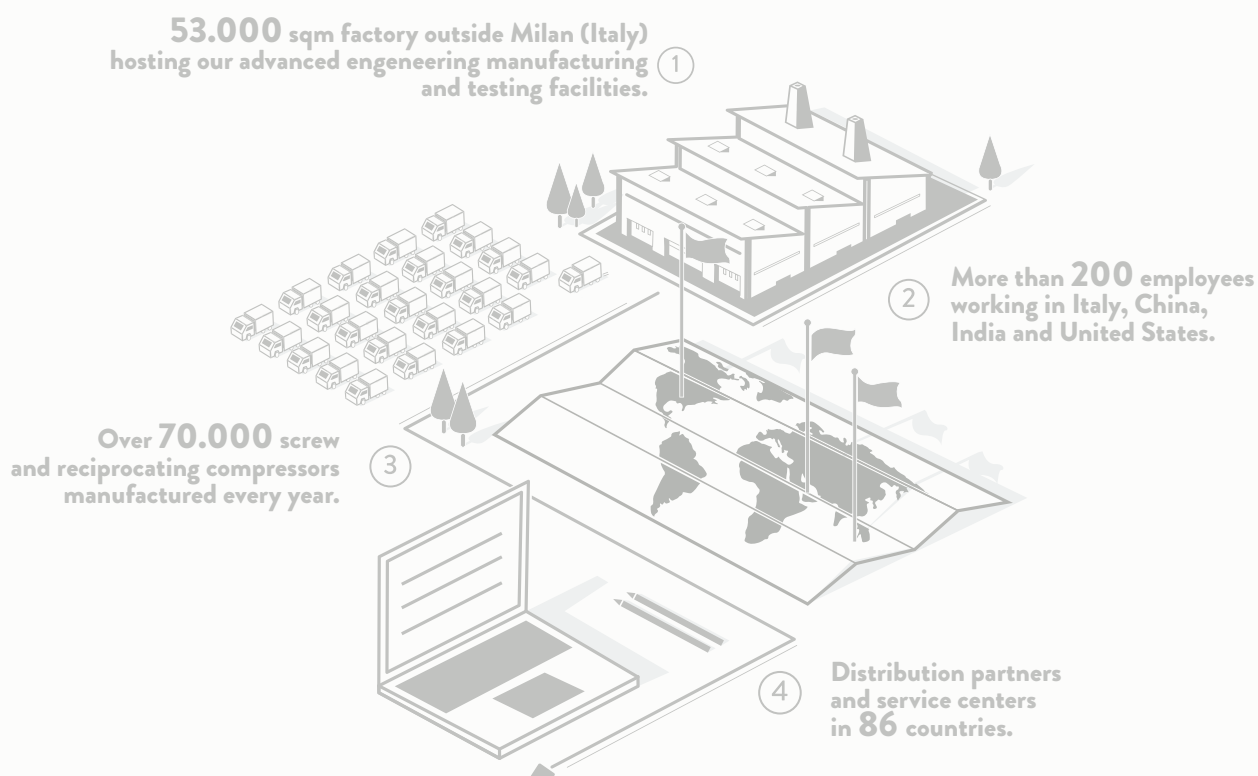

*More than 85 years ago Frascold was born as a small family owned Company developing solutions in refrigeration and conditioning industry. Today we invest more and more in people, products, technologies and services aiming to become the best partner for our Customers and the touchstone for the market.*

**GIUSEPPE GALLI** - Frascold Executive Managing Director

# SEGMENTS



# SOLUTIONS

Cooling capacity range @50Hz & @60Hz

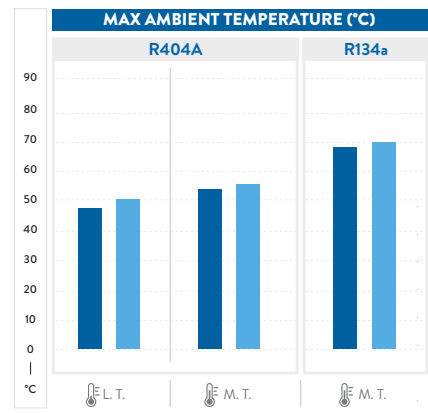
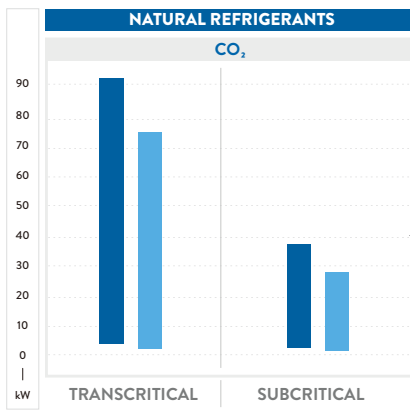
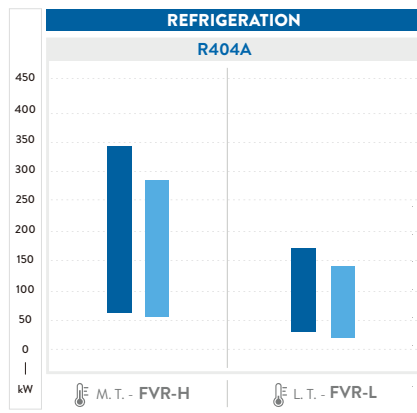
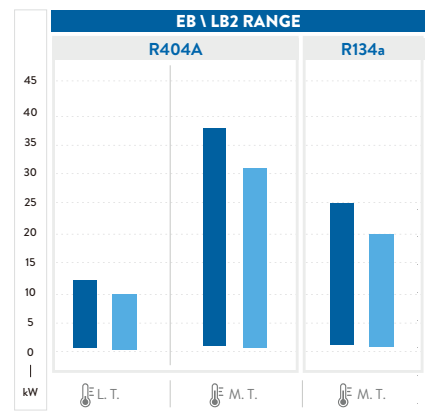
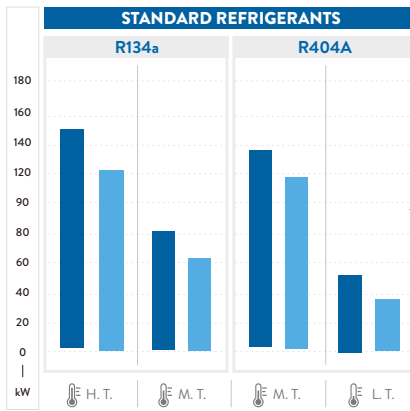
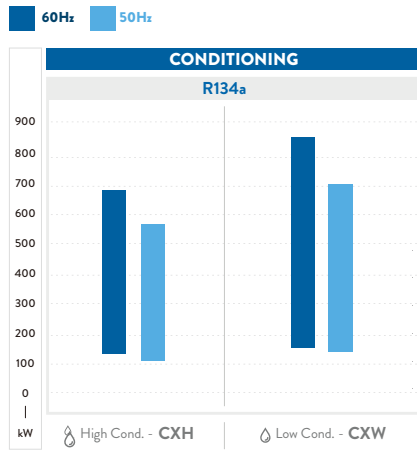



# SEMI-HERMETIC RECIPROCATING COMPRESSORS

Performance, reliability and efficiency: the 3 keywords when it comes to Frascold semi-hermetic reciprocating compressor range. This product line consists of 8 Series comprised of 81 models from 0,5 to 80HP and all the series can be powered by an inverter. Model from D, Q, S, V, Z & W are also compatible with our revolutionary new **Reduced Suction Head (RSH)** capacity control system and are suitable for variable frequency drive use.

# FEATURES & BENEFITS



*High efficiency*



*Silent operations*

Perfect mechanical balancing means low vibrations, pulsations and noise.



*Compact footprint*



*Refrigerants*

HFOs, HFCs and natural refrigerants.



*One year warranty*



*Advanced protection systems*



*RSH Capacity control (Optional)*



*All models VFD compatible*



*Flexibility*

The right compressor for any application: Air conditioning, Industrial refrigeration, Commercial refrigeration, Pharmaceutical manufacturing, HVAC chillers, Process chillers, Transport refrigeration, Marine cooling systems, Cryogenic systems & Heat pumps.

# CONFORMITY DECLARATION

**Frascold Reciprocating compressors** are intended for installation in refrigeration systems. The machine or partly completed machines shall comply with local safety regulation and standards of the place of installation (within the EU according to the EU Directives 2006/42/EC Machinery Directive, 2014/68/EU Pressure Equipment, 2006/95/EC Low Voltage Directive). They may be put into operation only if the compressor has been installed in accordance with these assembly instructions.

Commissioning is only possible if the entire system into which it is integrated has been inspected and approved in accordance to the provisions of legal regulations.

The Manufacturer Declaration describes the standards to be applied.

The Manufacturer Declaration of incorporation, according to the 2006/42/EC, is available at: [www.frascold.it](http://www.frascold.it)

8

## PERFORMANCE DATA FSS3 SOFTWARE

Please refer to our **FSS3** to check performances of all our compressors.



①

① Operating limits



②

② Cooling capacity



③

③ All operating data with any kind of refrigerant



④

④ European standard EN12900 at 50Hz



⑤

⑤ Technical information



⑥

⑥ Drawings



⑦

⑦ Manuals



⑧

⑧ Catalogues and certifications



# ASERCOM CERTIFICATION

## What is ASERCOM

ASERCOM (Association of European Refrigeration Component Manufacturers) promotes standards for safety and performance ratings in the refrigeration industry. ASERCOM certification means that a compressor's performance has been determined to meet the specifications stated by its manufacturer.

## How It Works

Manufacturer's performance data for a particular compressor model and refrigerant are submitted to ASERCOM for certification. To ensure objectivity, members of the certification committee are selected from competing manufacturers. If the committee agrees with the submitted performance data that model is added to the certified list.

## Performance Testing

Models from the certified list are regularly tested to verify performance. To ensure fairness, the compressor to be tested is obtained from a distributor's stock and tested at a competitor's facility. If test results are not up to the listed specifications that model is removed from the certified list.



Frascold stands behind the quality, performance and reliability of all of our products. We currently have 108 ASERCOM certified models and more on the way. All of our compressors are run tested at the factory and carry a standard 2 year warranty.

# ATEX

The ATEX directive (2014/34/UE) is a certification for equipment and protective systems intended for use in potentially explosive atmospheres, caused by the presence of gases or solid dust. **Our complete range of reciprocating and screw compressors (CX and FVR) is 100% certified** in category 3G: devices or protection systems that guarantee a very high level of protection Zone 2: an area where an explosive atmosphere may be present, but only in rare cases or for short periods. The compressor label includes the following ATEX assembly marking, usually placed on the wiring box:

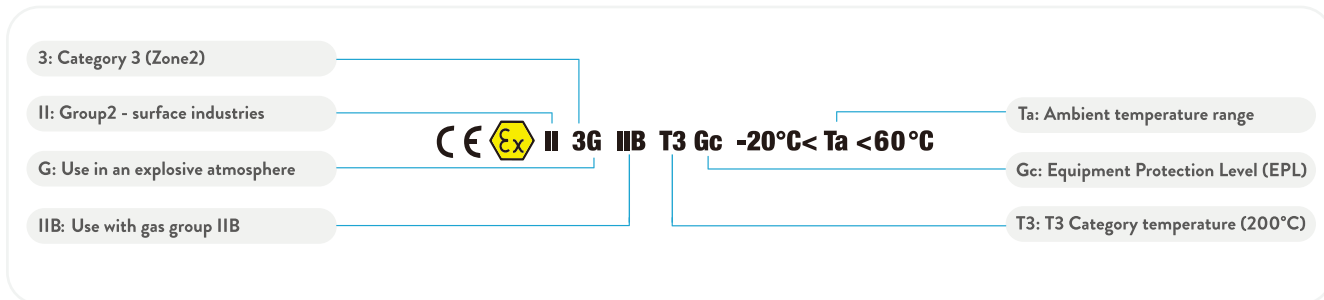

# COOLING CAPACITY AT 50Hz

Models: ■ A/B/D ■ Q/S ■ V ■ Z ■ W

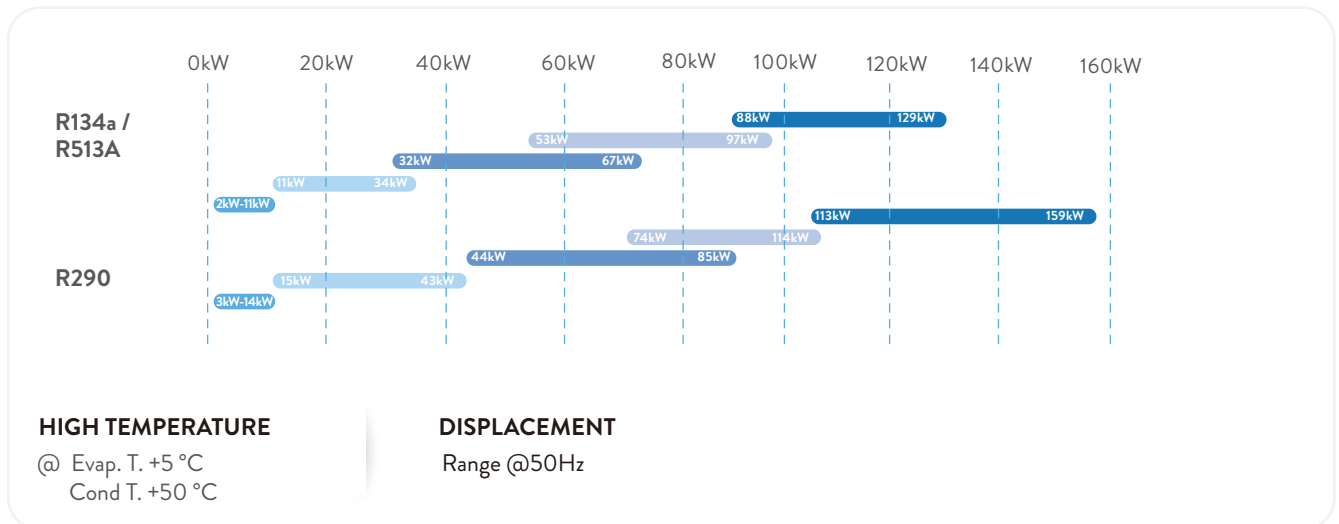
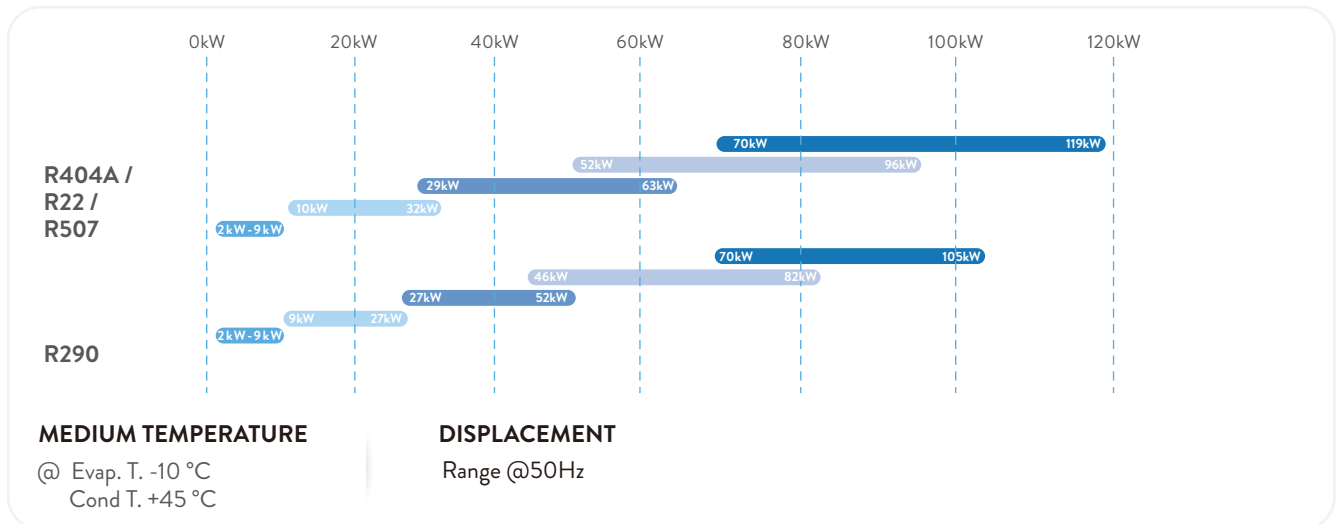
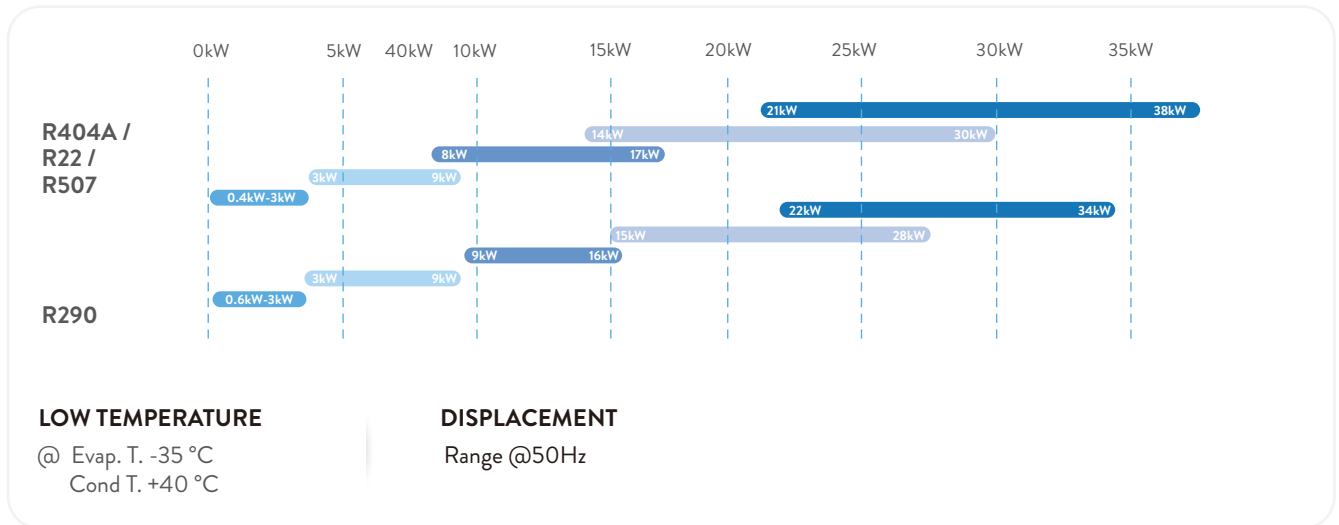

# COOLING CAPACITY AT 60Hz

Models: ■ A/B/D ■ Q/S ■ V ■ Z ■ W

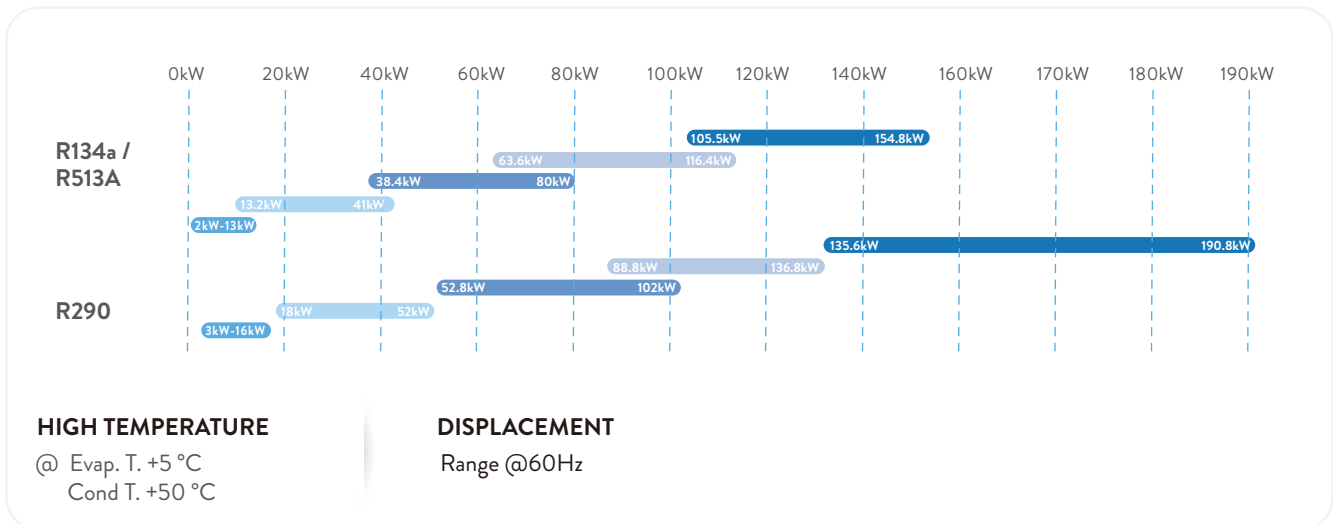
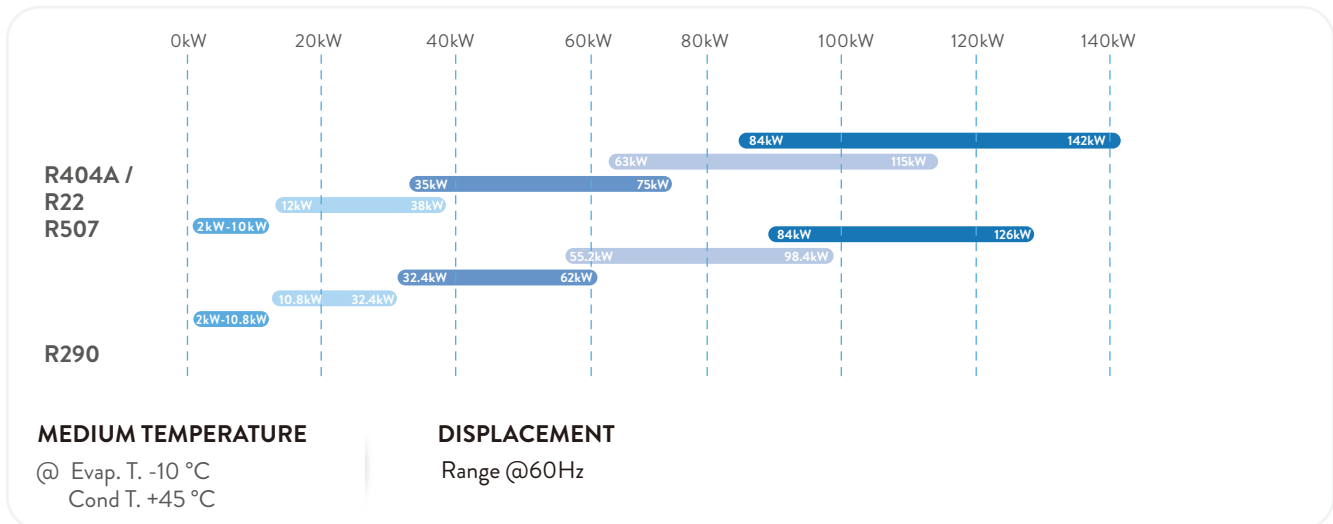
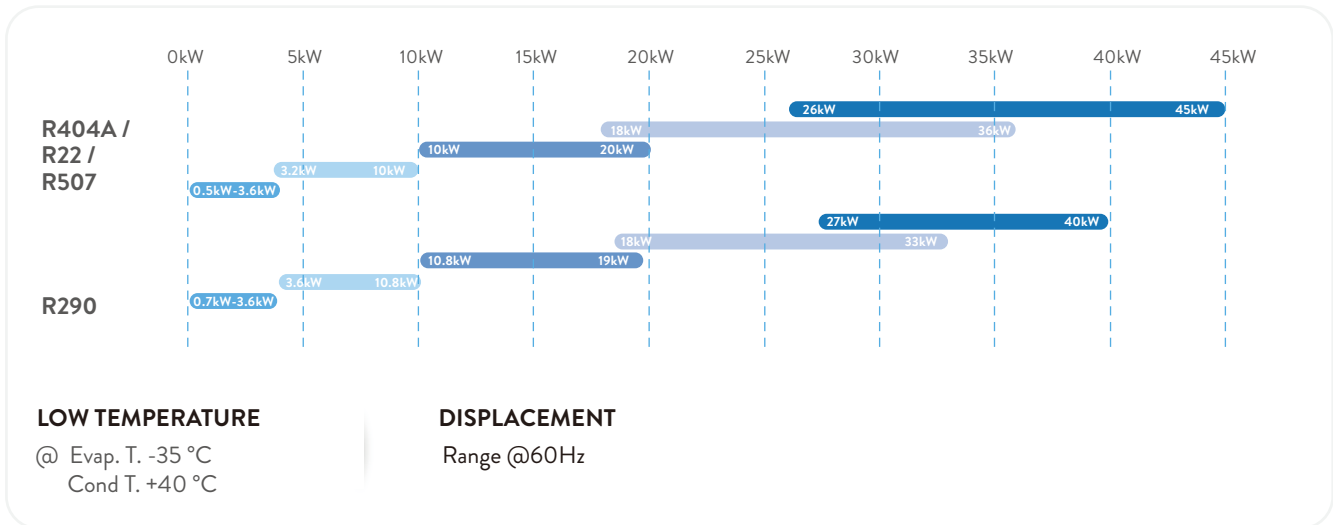

# PRODUCT RANGE

## SEMI HERMETIC RECIPROCATING

### A, B & D SERIES

2 Cylinders  
22 Models

0.5 - 4 HP

4 - 19 m<sup>3</sup>/h @50Hz | 4 - 22 m<sup>3</sup>/h @60Hz

4 - 40 HP

20 - 123 m<sup>3</sup>/h @50Hz | 24 - 148 m<sup>3</sup>/h @60Hz

### Q, S & V SERIES

4 Cylinders  
37 Models

### Z SERIES

6 Cylinders  
11 Models

25 - 50 HP

106 - 185 m<sup>3</sup>/h @50Hz | 127 - 222 m<sup>3</sup>/h @60Hz

40 - 80 HP

142 - 240 m<sup>3</sup>/h @50Hz | 170 - 288 m<sup>3</sup>/h @60Hz

### W SERIES

8 Cylinders  
11 Models

# MODEL DESIGNATION

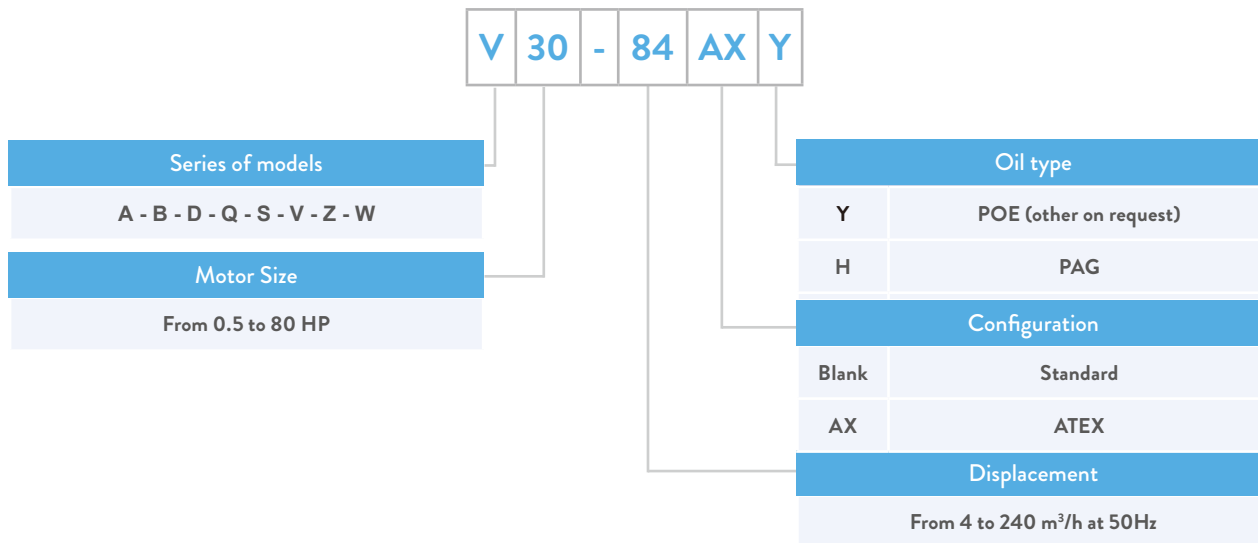

# INFORMATION PLATE

All the important information to identify the compressor is displayed on the nameplate. The date of production is contained in the serial number. The user is responsible for indicating the refrigerant type.

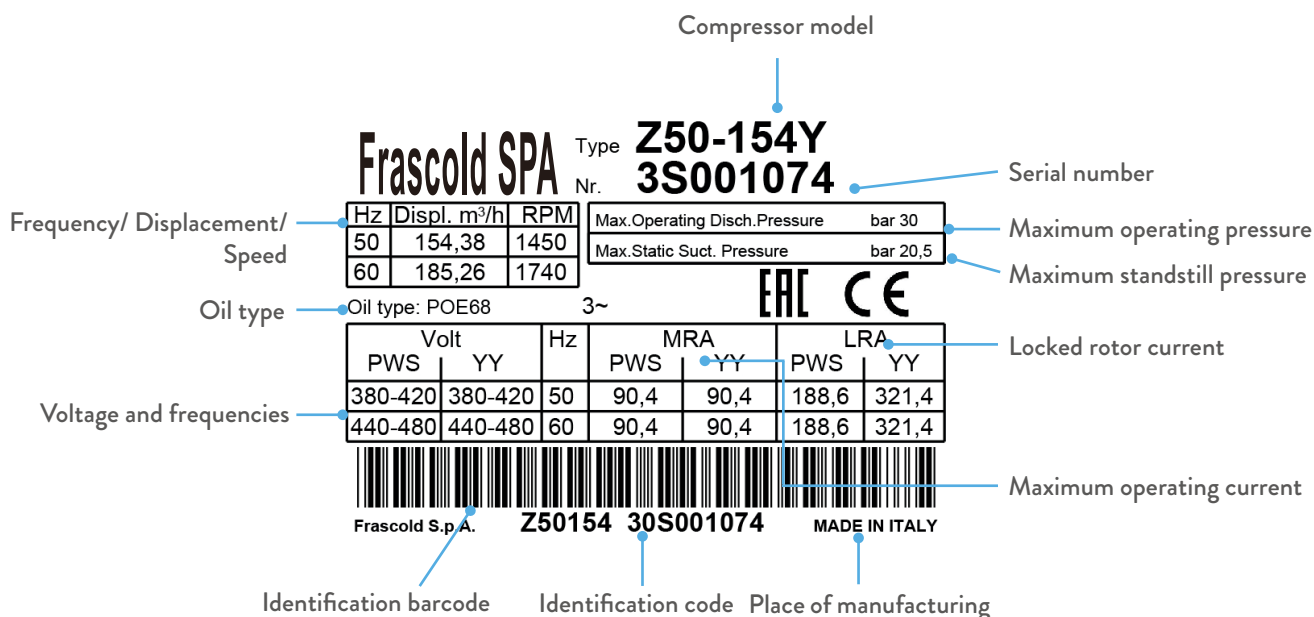

# STANDARD EQUIPMENT AND OPTIONAL ACCESSORIES

## Motor power supply

<b>A, B, D &amp; Q</b>	Semi-hermetic compressor with built-in electric motor DOL starting electric motor with thermal protection sensors connected to the electronic control module Δ = 50Hz/220-240V/3Ph (60Hz/265-290V/3pH) Y= 50Hz/380-420V/3Ph (60Hz/440-480V/3pH)265-290V Δ / 440-480V Y / 3 / 60Hz
<b>S, V, W &amp; Z</b>	Semi-hermetic compressor with built-in electric motor PWS starting electric motor with thermal protection sensors connected to the electronic control module PWS (Y/YY)= 380-420V/3Ph/50Hz (440-480V/3pH/ 60Hz) DOL (YY)= 380-420V/3Ph/50Hz (440-480V/3pH/ 60Hz)

14

Description	Series							
	A-B		D		Q-S		V-Z-W	
	Std.	Opt.	Std.	Opt.	Std.	Opt.	Std.	Opt.
Electric terminal box IP class protection (IP56 For Series A,B,D,Q & S, IP65 For Series V,Z & W)	•		•		•		•	
Thermistor	•		•		•		•	
Control and protection device (INT69)	•		•		•			
Control, diagnostics & protection device (INT69 Diagnose and INT69 TML Diagnose)		•		•		•		•
Discharge temperture control sensor							•	
Electronic oil differential pressure switch								•
Reversible oil pump								•
Oil level sight glass (Two for Series Q,S,V,Z,& W)	•		•		•		•	
Oil charge (POE32 For Series A,B,D,Q & S, POE68 For Series V,Z & W)	•		•		•		•	
Liquid injection connection					•		•	
Suction shut-off valve	•		•		•		•	
Discharge shut-off valve	•		•		•		•	
Nitrogen charge (2bar min)	•		•		•		•	
Rubber supports	•		•		•		•	
Oil heater	•		•		•		•	
US unloader start head				•		•		•
RSH capacity control head				•		•		•
CC capacity control head						•		•
Head cooling fan		•		•		•		•
Liquid injection kit (FLI)						•		•
Optoelectronic oil level switch						•		•
Kit adapters for oil equalization line		•		•		•		•
DP-Modbus Gateway		•		•		•		•
Connection cable Modbus Gateway - INT69		•		•		•		•
USB adapter cable		•		•		•		•
Bluetooth module for Diagnose		•		•		•		•

# CONTROL PROTECTION DEVICE

---

## Discharge Temperature Cutoff

The discharge temperature in certain extreme conditions (such as high condensing temperatures, low evaporating pressures or extremely high compression ratios), may reach values that can damage the compressor. All V, Z and W series models are supplied with a **safety device** which, in combination with the electronic control module, stops the compressor in the event that the discharge temperature exceeds the set safety limit.

## Electronic Safety Device to control lubrication

Frascold compressors in the V, Z and W series are supplied complete with an **electronic pressure switch** to control lubrication. It monitors the differential pressure in the lubrication system and stops the compressor in the event of any detected measurement that does not comply with the set safety values. The device is attached directly to the compressor's oil pump and does not require additional fittings.

## INT69 ®

Standard protection equipment on A, B, D, Q and S series compressors consists of a chain of PTC or AMS thermistors inserted in the electric motor stator and connected to the **Kriwan INT69 ®** electronic control module inside the electrical box. The **INT69®** device is triggered and stops the compressor in the event of thermal overload due to electric motor or mechanical issues.

## INT69 ® Diagnose

**Kriwan INT69 ® Diagnose** protection device provides all of the protection of the **INT69 ®** with advanced diagnostic and communication functions, allowing the compressor to be remotely monitored in real time via modbus. System conditions are monitored and the compressor is stopped in the event of incorrect functional parameters. Detailed reporting allows quick identification of the cause of the malfunction. Stored data allows technicians to accurately and quickly diagnose the past and present state of the cooling system, ensuring fast and cost-effective servicing with short system downtime. **Kriwan INT69® Diagnose** is optional for all models from A to S series.

## INT69 TML Diagnose

**Kriwan INT69 TML Diagnose** protection device. This unit provides all of the protection data logging and remote monitoring capabilities of the **INT69 ®** and **INT69 ® Diagnose** but with the addition of lubrication protection. Frascold V, Z and W series compressors come standard with **INT69 TML ® Diagnose** module.

# CAPACITY REGULATION

Frascold reciprocating compressors capacity can be regulated with:

1. CAPACITY CONTROL (CC)
2. REDUCED SUCTION HEADS (RSH)
3. VARIABLE FREQUENCY DRIVE (VFD)

## CAPACITY CONTROL (CC)

Frascold offers a standard capacity control feature. Available on request on 4, 6 and 8-cylinder compressors, capacity may be adjusted by choking the heads in order to adapt the cooling capacity of the system to the actual thermal demand. This reduces the number of start-stop cycles and the stress on the compressor mechanics and electric motor. **Possible control stages:**

	4 Cylinder	6 Cylinder	8 Cylinder
2 Steps	50 / 100%		
2 or 3 Steps		66 / 100%	50 / 75 / 100%

16

## REDUCED SUCTION HEADS (RSH)

Frascold's patented Reduced Suction Head (RSH) unloading technology represents a revolution in capacity control for reciprocating compressors, avoiding problems caused by traditional unloading methods. By allowing 50% gas flow to the unloaded cylinder head, RSH equipped systems:

- Can run unloaded indefinitely with no additional vibration, heat and stress to the motor vs. standard unloading methods.
- Match more accurately fluctuating cooling demand, saving a significant amount of energy over traditional unloading.

**RSH** unloading is available exclusively from Frascold and can be fitted to any Frascold reciprocating compressor (2, 4, 6 and 8 cylinders). With more unloading steps and the ability to run unloaded indefinitely, **RSH** equipped systems provide greater application flexibility and energy costs can be significantly reduced. Fewer start-stop cycles means increased service life, less downtime and lower maintenance costs.

RSH Heads	2 Cylinder	4 Cylinder	6 Cylinder	8 Cylinder
1	50 / 100%	75 / 100%	83 / 100%	87.5 / 100%
2		50 / 75 / 100%	66 / 83 / 100%	75 / 87.5 / 100%
3			50 / 66 / 83 / 100%	62.5 / 75 / 87.5 / 100%
4				50 / 62.5 / 75 / 87.5 / 100%



## VARIABLE FREQUENCY DRIVE VFD

All Frascold compressors are designed to be compatible with inverter technology. Inverters, also known as variable frequency drives, can greatly improve performance and efficiency in many applications.

(For 400V motors in certain application conditions there might be a narrowing of the frequency range. Always check on the Frascold Selection Software. For capacity data at the various frequencies see the Frascold selection software FSS3.)

### A-B-D Series Operating range

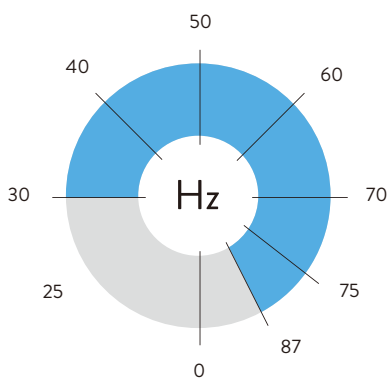

17

### Q-S Series Operating range

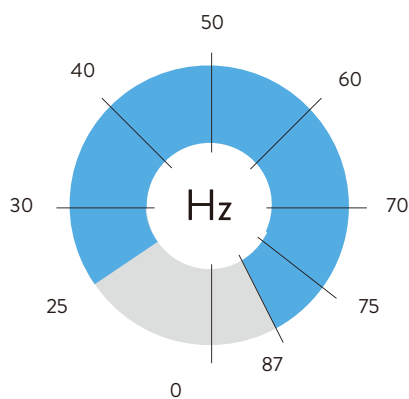

### V-Z-W Series Operating range

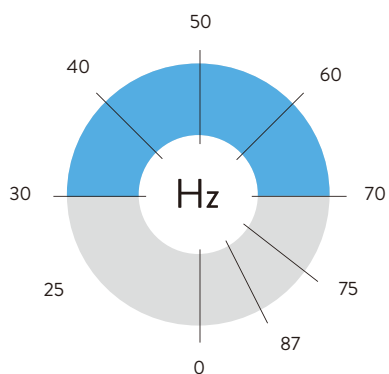

# TECHNICAL DATA AND OPERATING LIMITS

---

## Reciprocating Compressors

**LEGAL DISCLAIMER:**

While Frascold has made every effort at the time of publication to ensure the accuracy of the information provided herein, product specifications and performances could be subject to change without notice.

You can find the most updated information in our Product Selection Software FSS3 at the link: <https://www.frascold.it/en/software>

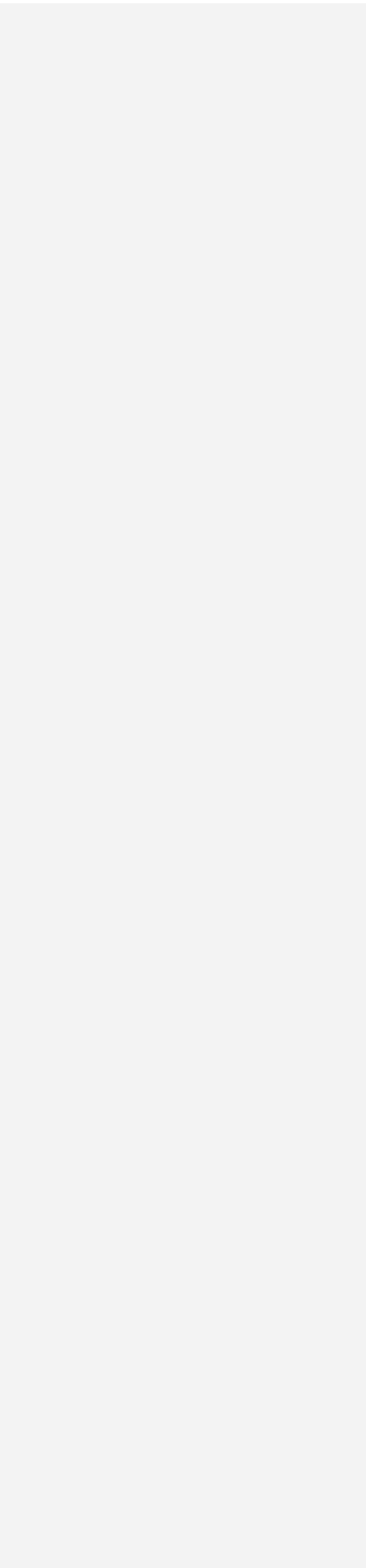

## Reciprocating compressors

### Motor power supply

220-240V (Δ) - 380-420V (Y) / 3ph / 50Hz | 265-290V (Δ) - 440-480V (Y) / 3ph / 60Hz | DOL connection

Model	Cylinders	Displacement		Oil Charge (3/4 of sightglass)	Motor Ver.	Standard		AXH		LRA Locked motor current DOL motor	
		50Hz	60Hz			MRA max operating current		MRA max operating current		LRA Locked motor current	
		[m <sup>3</sup> /h]				Δ	Y	Δ	Y	Δ	Y
		[l]				[A]		[A]		[A]	
A05-4Y	2	3,95	4,74	1	1	4,9	2,8	4,9	2,5	18,6	10,7
A05-5Y	2	4,93	5,92	1	2	4,7	2,7	4,7	2,4	18,6	10,7
A07-5Y	2	4,93	5,92	1	1	4,7	2,7	4,7	2,6	18,6	10,7
A07-6Y	2	5,47	6,56	1	2	4,9	2,8	4,9	2,8	18,6	10,7
A1-6Y	2	5,47	6,56	1	1	6,2	3,6	6,3	3,6	23,6	13,6
A1-7Y	2	6,91	8,29	1	2	6,4	3,7	6,4	4,3	23,6	13,6
A1.5-7Y	2	6,91	8,29	1	1	7,9	4,5	7,9	4,7	35,8	20,6
A1.5-8Y	2	7,65	9,18	1	1	8,4	4,8	7,5	4,3	35,8	20,6
B1.5-9.1Y	2	8,96	10,75	1	2	10,2	5,9	10,2	6,1	46,6	26,8
B1.5-10.1Y	2	9,88	11,86	1	2	9,5	5,5	9,5	5,5	46,6	26,8
B2-10.1Y	2	9,88	11,86	1	1	11,7	6,7	10,4	6	62,5	35,9
D2-11.1Y	2	11,26	13,51	1,1	1	12,4	7,1	11,1	6,4	62,5	35,9
D2-13.1Y	2	13,15	15,78	1,1	2	12,4	7,1	11,6	6,7	62,5	35,9
D3-13.1Y	2	13,15	15,78	1,1	1	15,3	8,8	15,3	8,6	75,9	43,7
D2-15.1Y	2	15,36	18,43	1,1	2	14,6	8,4	14,6	7,7	62,5	35,9
D3-15.1Y	2	15,36	18,43	1,1	1	17,6	10,1	17,5	9	75,9	43,7
D3-16.1Y	2	16,4	19,68	1,1	2	17,2	9,9	17,2	8,3	75,9	43,7
D4-16.1Y	2	16,4	19,68	1,2	1	20,1	11,6	20,1	10,7	90,3	52
D3-18.1Y	2	17,93	21,52	1,1	2	17,3	10	17,3	9,7	75,9	43,7
D4-18.1Y	2	17,93	21,52	1,2	1	21,7	12,5	20,5	11,8	90,3	52
D3-19.1Y	2	19,12	22,94	1,1	2	17	9,8	17	10,3	75,9	43,7
D4-19.1Y	2	19,12	22,94	1,2	1	20,5	11,8	20,6	11,9	90,3	52
Q4-20.1Y	4	19,77	23,72	1,6	2	17,5	10,1	15,6	9	92,6	53,2
Q4-21.1Y	4	21,18	25,42	1,6	2	17,3	10	16,5	9,5	92,6	53,2
Q5-21.1Y	4	21,18	25,42	1,6	1	20,1	11,6	18,8	10,8	110	63,1
Q4-24.1Y	4	23,91	28,69	1,6	2	20,3	11,7	18	10,4	92,6	53,2
Q5-24.1Y	4	23,91	28,69	1,6	1	23,9	13,8	23,9	13,8	110	63,1
Q4-25.1Y	4	24,69	29,63	1,6	2	19,1	11	18,4	10,6	92,6	53,2
Q5-25.1Y	4	24,69	29,63	1,6	2	22,1	12,7	23,1	13,3	110	63,1
Q7-25.1Y	4	24,69	29,63	1,6	1	26,8	15,4	26,8	14,7	152	87,3
Q5-28.1Y	4	28,02	33,62	1,6	2	24,3	14	20,8	12	110	63,1
Q7-28.1Y	4	28,02	33,62	1,6	1	30,7	17,6	30,3	17,4	152	87,3
Q5-33.1Y	4	32,66	39,19	1,6	2	25	14,4	25	14,5	110	63,1
Q7-33.1Y	4	32,66	39,19	1,6	1	34,7	20	34,7	20,6	152	87,3
Q7-36.1Y	4	35,86	43,03	1,6	1	33,6	19,4	34,3	20,4	152	87,3

Tolerance ±10% compared to the average value of the motor voltage range. Other voltages are available on request.  
To select contactors, cables and fuses, consider the MRA and the maximum absorbed power.  
Use AC3 category contactors.

Find the most updated information and other supply voltages in our Product Selection Software FSS3 at the link:  
<https://www.frascold.it/en/software>

## Motor power supply

380-420V (Y) / 3ph / 50Hz | 440-480V (Y) / 3ph / 60Hz | PWS connection

Model	Cylinders	Displacement		Oil Charge (3/4 of sightglass)	Motor Ver.	Standard	AXH	LRA locked motor current PWS motor
		50Hz	60Hz			MRA max operating current		
		[m <sup>3</sup> /h]				[A]		
S5-33Y	4	32,8	39,36	2,9	2	15,9	15,5	35,5
S7-33Y	4	32,8	39,36	2,9	1	20,4	18,9	47
S8-42Y	4	41,32	49,58	2,9	2	20,3	19,5	52,7
S12-42Y	4	41,32	49,58	2,9	1	22,4	21,6	59,1
S10-52Y	4	51,5	61,8	2,9	2	24,5	22	59,1
S15-52Y	4	51,5	61,8	2,9	1	32,4	28,7	74,8
S15-56Y	4	56	67,2	2,9	2	30,7	26,6	74,8
S20-56Y	4	56	67,2	2,9	1	38,4	35,9	87,5
S20-63Y	4	63,2	75,84	2,9	2	33	28,3	102
S25-63Y	4	63,2	75,84	2,9	1	39,5	37,9	112
V15-59Y	4	58,48	70,18	4	2	31,1	26,8	74,8
V20-59Y	4	58,48	70,18	4	1	35,3	30,2	107
V15-71Y	4	70,77	84,92	4	2	32,2	31,5	74,8
V25-71Y	4	70,77	84,92	4	1	43,5	36,9	118
V20-84Y	4	83,81	100,57	4	2	42,6	36,2	107
V30-84Y	4	83,81	100,57	4	1	49,2	44	132,6
V25-93Y	4	93,05	111,66	4	2	52,3	39,6	118,3
V32-93Y	4	93,05	111,66	4	1	53,1	42,8	144,5
V25-103Y	4	102,9	123,48	4	2	52,3	42,2	118,3
V35-103Y	4	102,9	123,48	4	1	61	47	144,5
V30-112Y	4	112,11	134,53	4	2	56	45,6	132,6
V35-112Y	4	112,11	134,53	4	1	67,5	63,4	144,5
V30-123Y	4	123,13	147,76	4	2	60,5	51,5	132,6
V40-123Y	4	123,13	147,76	4	1	76,5	70,3	159,2
Z25-106Y	6	106,16	127,39	3,7	2	53,6	43,9	118,3
Z35-106Y	6	106,16	127,39	3,7	1	60,2	53,9	144,5
Z30-126Y	6	125,72	150,86	7,2	2	55,7	51	132,6
Z40-126Y	6	125,72	150,86	7,2	1	71,9	61	159,2
Z40-140Y	6	139,68	167,62	7,2	2	70	64,2	159,2
Z50-140Y	6	139,68	167,62	7,2	1	79,5	67	188,6
Z40-154Y	6	154,38	185,26	7,2	2	77,9	71,5	159,2
Z50-154Y	6	154,38	185,26	7,2	1	90,4	74,6	189
Z40-168Y	6	168,16	201,79	7,2	2	77,9	71,5	159
Z50-168Y	6	168,16	201,79	7,2	1	90,4	74,6	189
Z50-185Y	6	184,7	221,64	7,2	2	90,4	74,6	189
W40-168Y	8	167,6	201,12	7,7	2	71,4	73,7	215
W50-168Y	8	167,6	201,12	7,7	1	94,8	89,3	258
W50-187Y	8	186,1	223,32	7,7	2	89,1	87,3	258
W60-187Y	8	186,1	223,32	7,7	1	103,5	99,8	326
W60-206Y	8	205,8	246,96	7,7	2	98,8	85,4	326
W70-206Y	8	205,8	246,96	7,7	1	116,8	103	390
W70-228Y	8	227,77	273,32	7,7	2	109,5	94,2	390
W75-228Y	8	227,77	273,32	7,7	1	128,4	108	417
W75-240Y	8	239,02	286,82	7,7	2	115,3	102	417
W80-240Y	8	239,02	286,82	7,7	1	135,7	111	417

Data reference valid for the same model in ATEX version (except MRA for AXH models).

# COMPRESSOR ENVELOPE

Diagrams published in this catalog are to be considered as a general diagram for the full range of semi-hermetic reciprocating compressors. For specific model and refrigerant performance data, please use the **FSS3 Frascold Selection Software** available for free download at <https://www.frascold.it/en/software>

**Motor 1** - Medium temperature applications

**Motor 2** - Low temperature applications

## R22

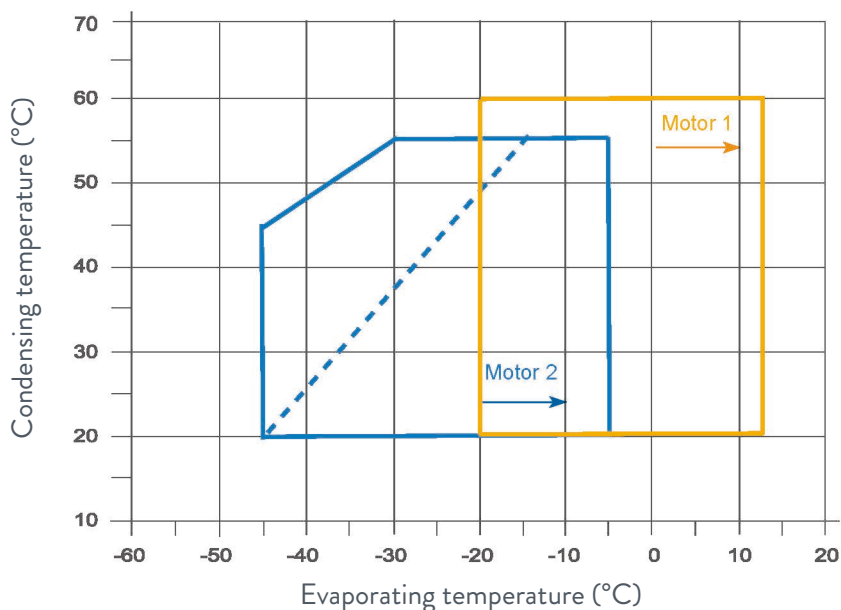

### Standard application diagram

Motor size 1 - 2  
Compressor capacity 100%  
Suction gas temperature 20°C

## R404A - R507A

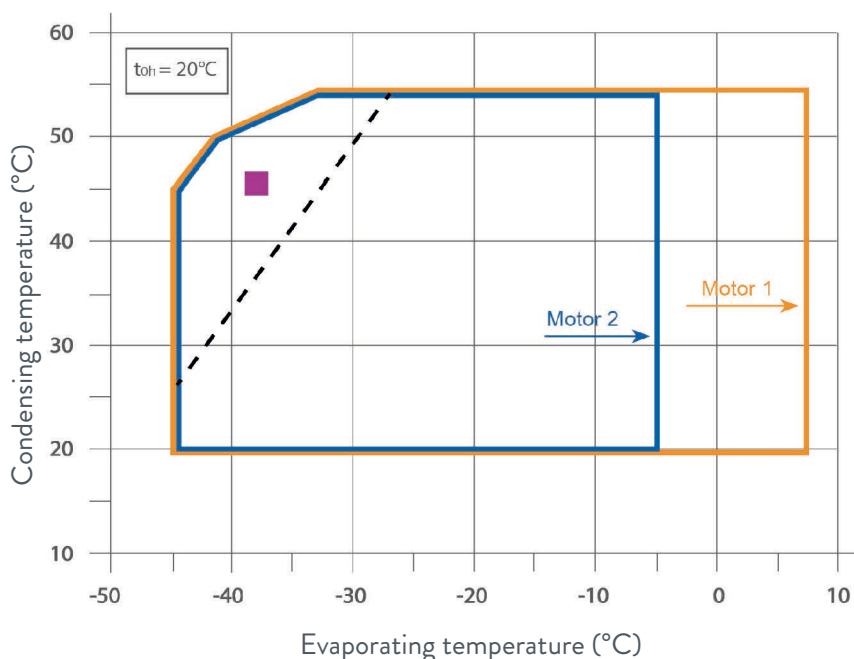

### Standard application diagram

Motor size 1 - 2  
Compressor capacity 100%  
Suction gas temperature 20°C

Find the most updated information in our Product Selection Software FSS3 at the link : <https://www.frascold.it/en/software>

## R450A - R513A

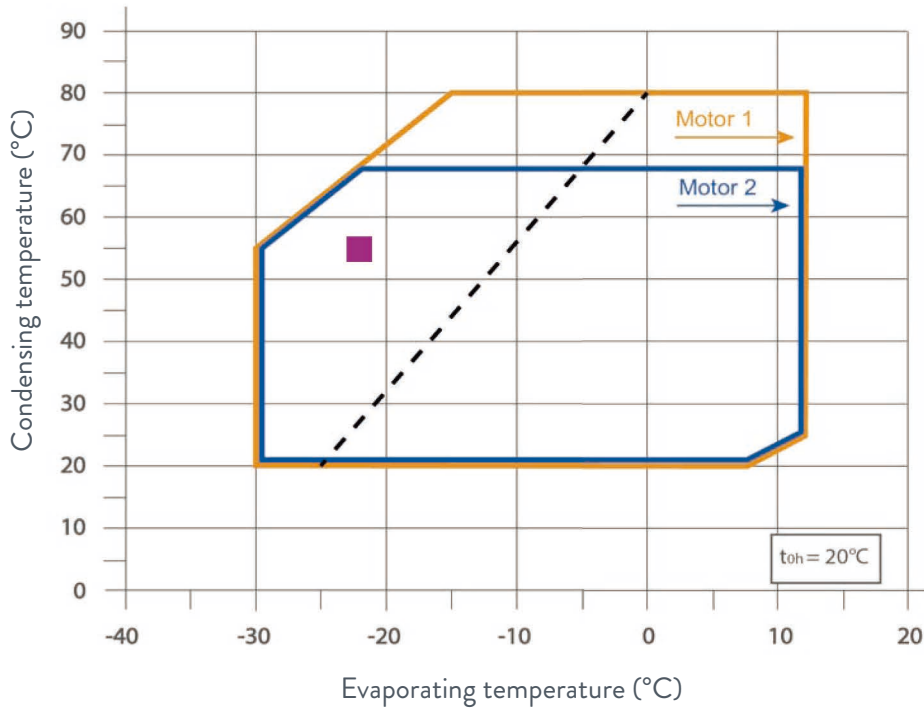

### Standard application diagram

Motor size 1 - 2  
Compressor capacity 100%  
Suction gas temperature 20°C

## R448A - R449A

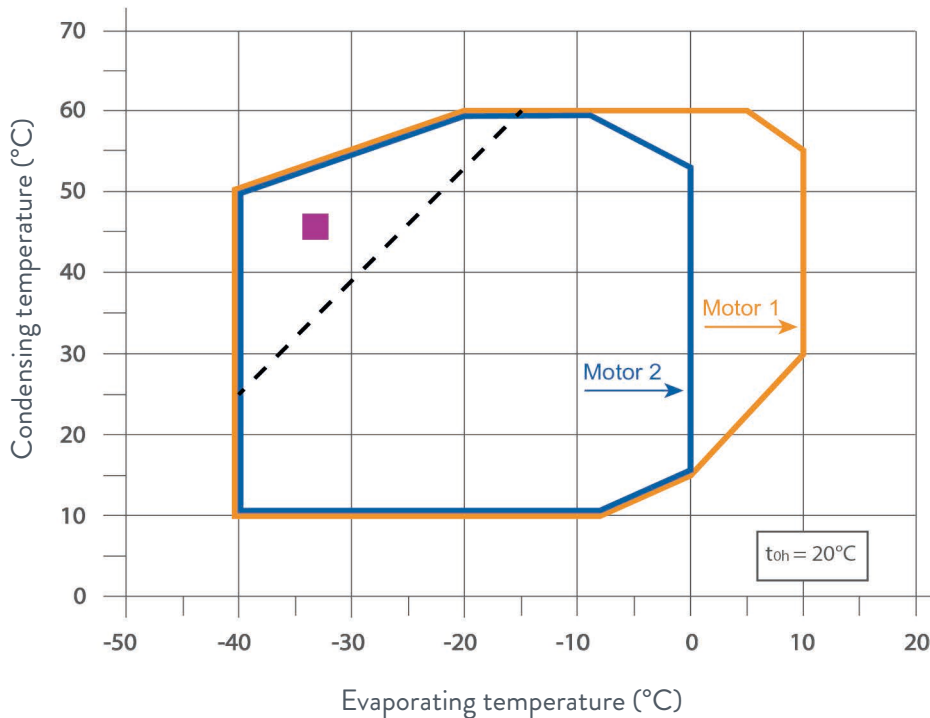

### Standard application diagram

Motor size 1 - 2  
Compressor capacity 100%  
Suction gas temperature 20°C

■ For additional cooling or superheat reduction or for performance data on a specific compressor model, please refer to Frascold selection software FSS3

### R407F - R407A

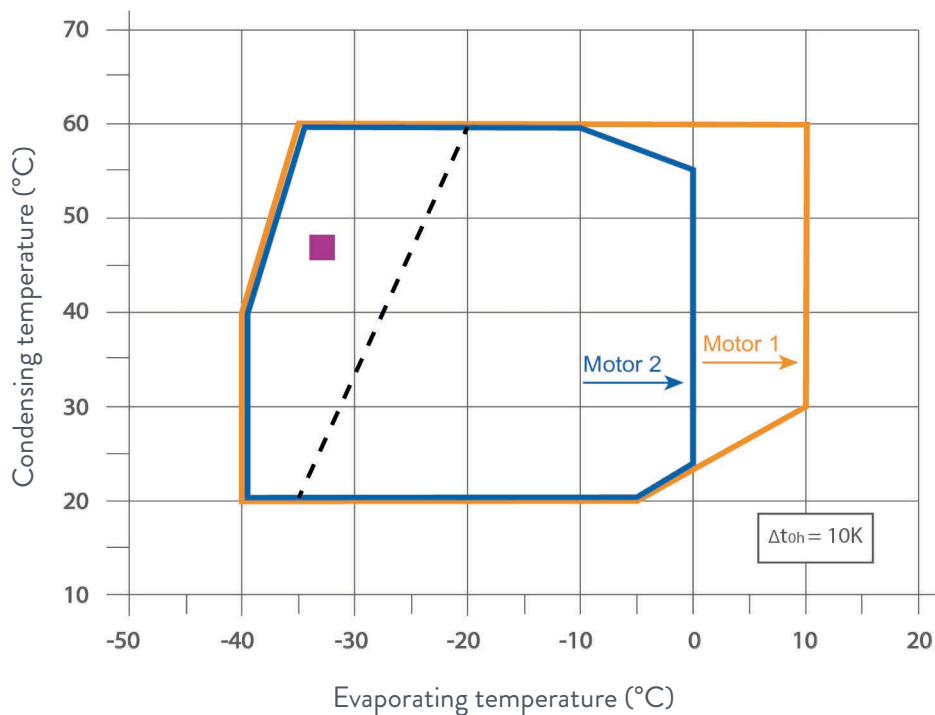

**Standard application diagram**

Motor size 1 - 2  
 Compressor capacity 100%  
 Suction gas temperature 20°C

### R407C

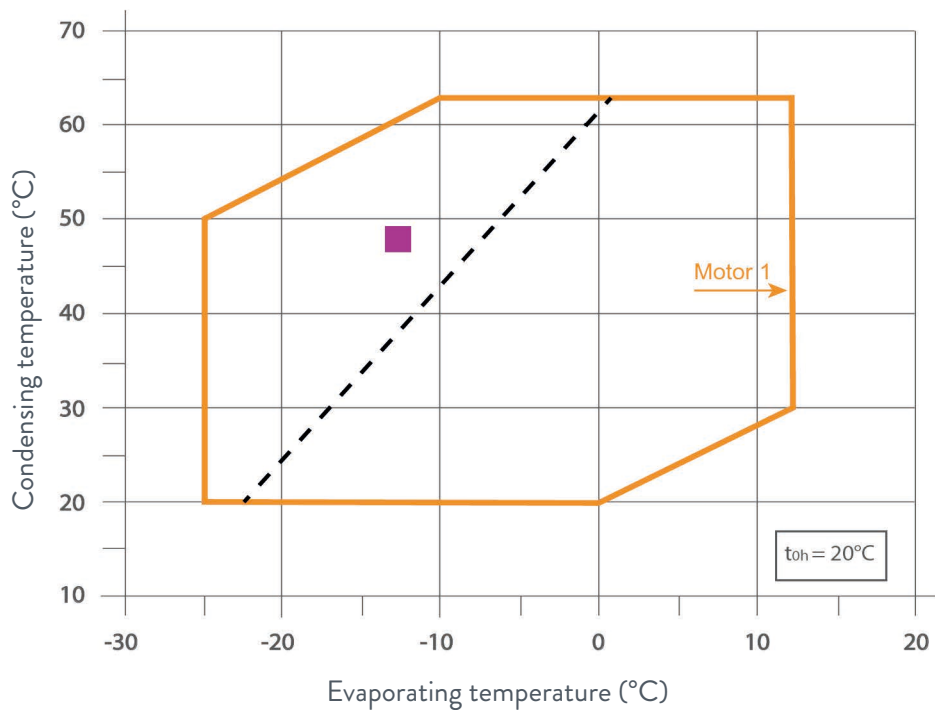

**Standard application diagram**

Motor size 1  
 Compressor capacity 100%  
 Suction gas temperature 20°C



## R134a

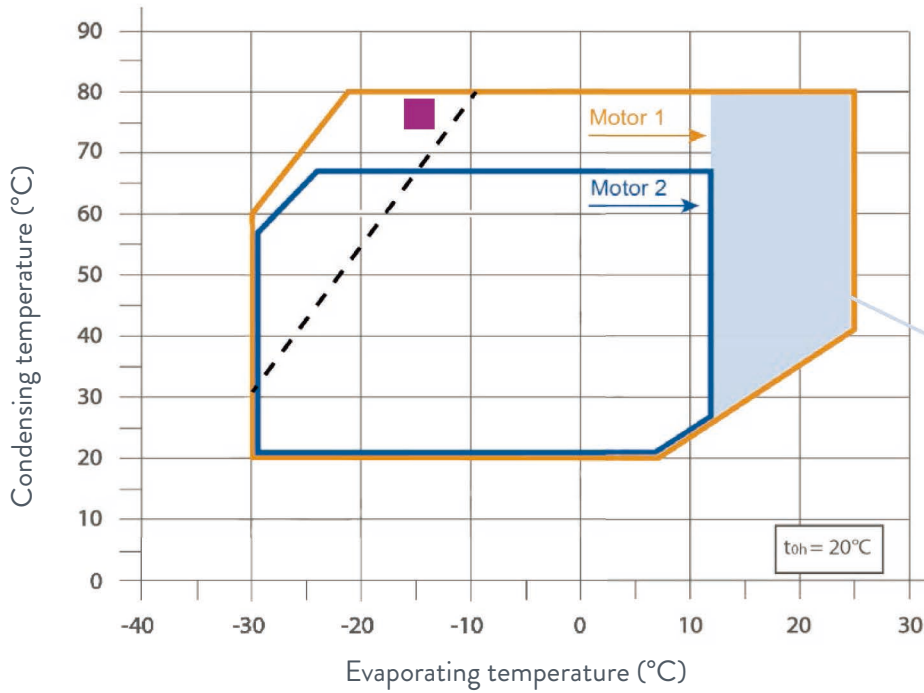

### Standard application diagram

Motor size 1 - 2  
Compressor capacity 100%  
Suction gas temperature 20°C

For operation in this area please contact Frascold

## R290

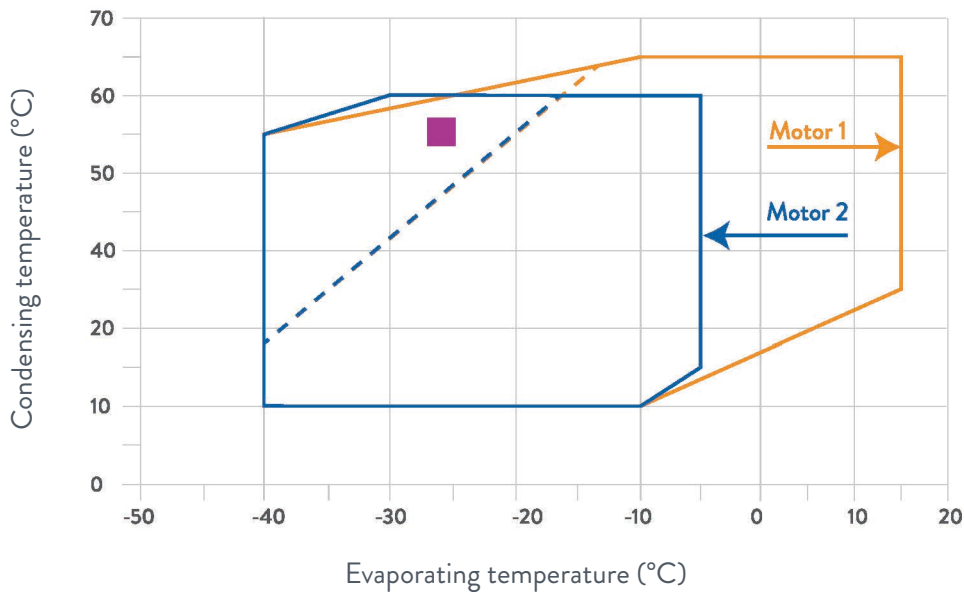

### Standard application diagram

Motor size 1 - 2  
Compressor capacity 100%  
Suction gas temperature 20°C

use R290  
please contact Frascold

■ For additional cooling or superheat reduction or for performance data on a specific compressor model, please refer to Frascold selection software FSS3

# TECHNICAL DRAWINGS AND DIMENSIONS

26

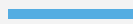

Reciprocating Compressors

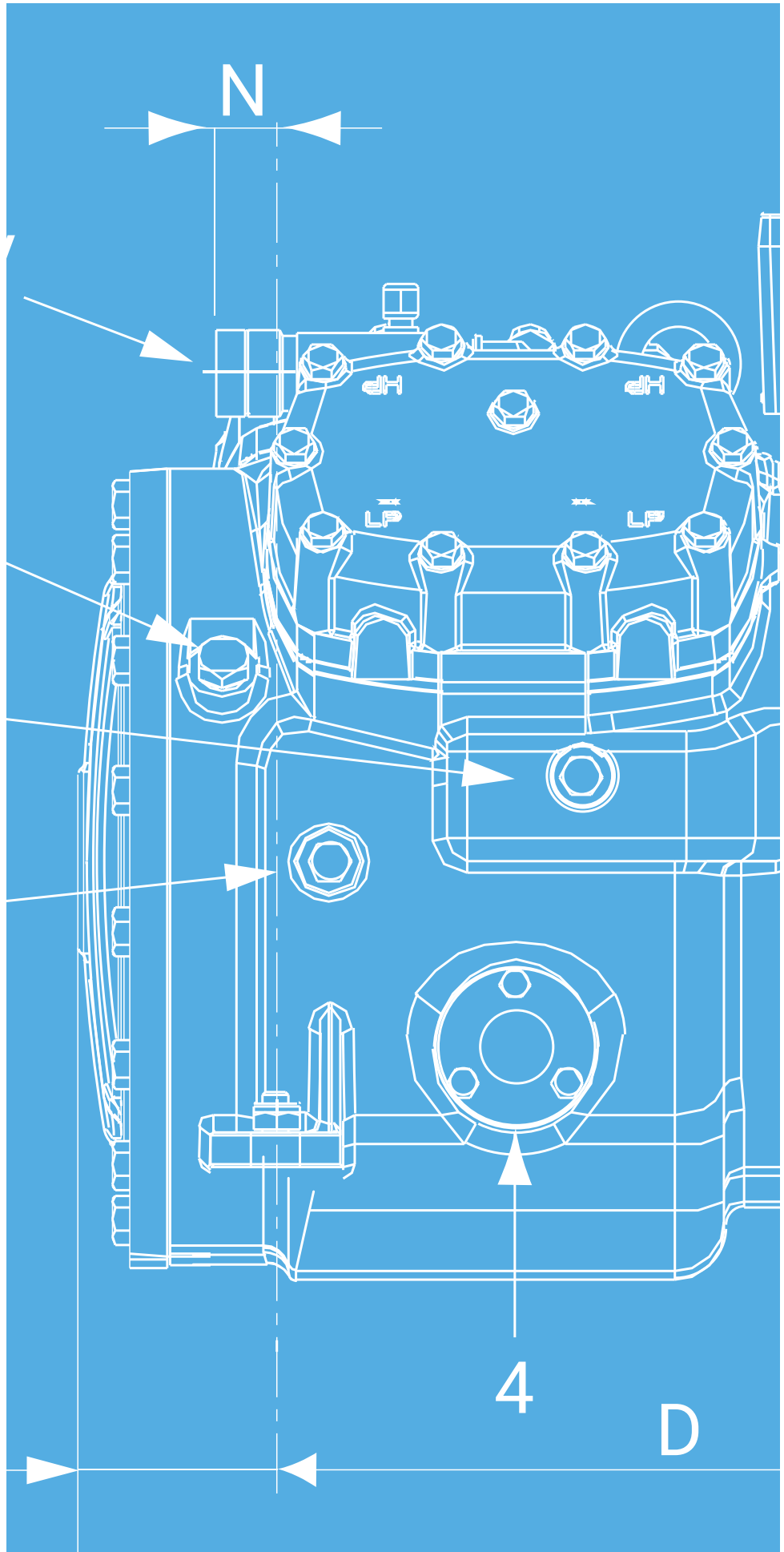

## Dimensional drawing

### A Series

	Compressor					Valves position						Valves				Net Weight [Kg]
	Length	Width	Height	Base mounting		Suction			Discharge			Suction		Discharge		
	A	B	C	D	E	F	G	H	L	M	N	Ø		Ø		
	[mm]	[mm]	[mm]	[mm]	[mm]	[mm]	[mm]	[mm]	[mm]	[mm]	[mm]	[inch]	[mm]	[inch]	[mm]	
A05-4Y	317	237	275	234	194	150	209	29	97	167	18	5/8"	15,8	1/2"	12,7	36
A05-5Y																
A07-5Y																
A07-6Y																
A1-6Y																
A1-7Y																
A1.5-7Y																
A1.5-8Y																

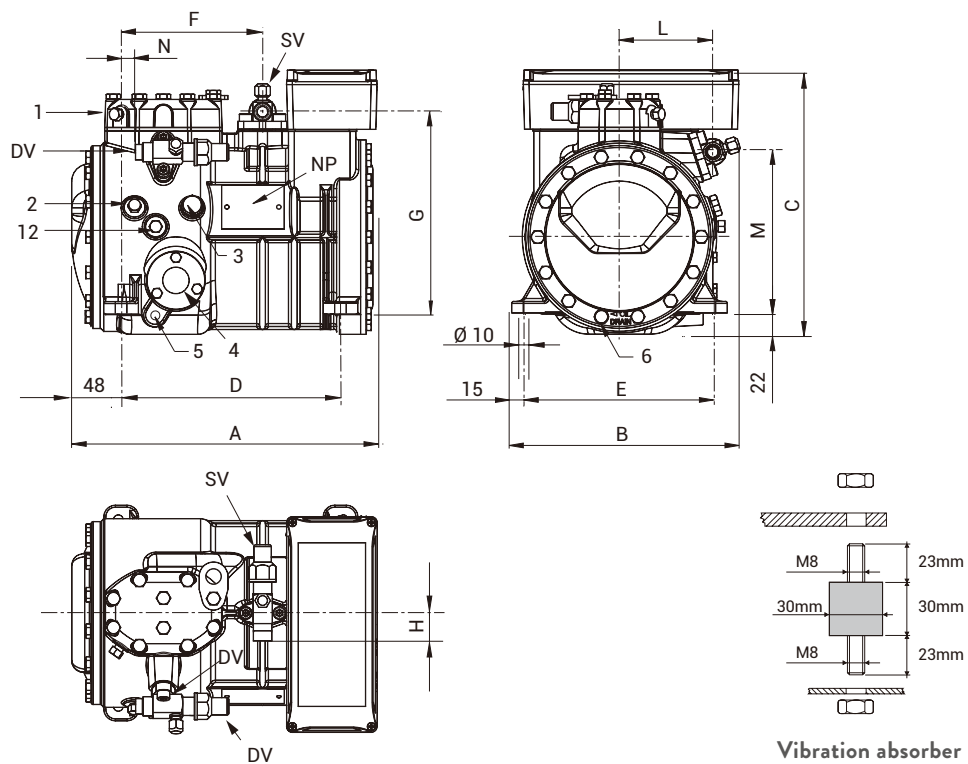

28

1	High pressure plug	1/8" NPT
2	Low pressure plug	1/8" NPT
3	Oil charge plug	1/4" GAS
4	Oil level sight glass	
5	Crankcase heater socket	
6	Oil drain plug	M8 x 22
12	Oil return plug	1/8" NPT
DV	Discharge valve	
SV	Suction valve	
NP	Nameplate	

## Dimensional drawing

### B Series

	Compressor					Valves position						Valves				Net Weight [Kg]
	Length	Width	Height	Base mounting		Suction			Discharge			Suction		Discharge		
	A	B	C	D	E	F	G	H	L	M	N	Ø		Ø		
	[mm]	[mm]	[mm]	[mm]	[mm]	[mm]	[mm]	[mm]	[mm]	[mm]	[mm]	[inch]	[mm]	[inch]	[mm]	
B1.5-9.1Y	329	237	292	234	194	150	209	29	97	167	18	5/8"	15,8	1/2"	12,7	38
B1.5-10.1Y																
B2-10.1Y	334	237	292	234	194	150	209	31	97	167	18	3/4"	19,0	5/8"	15,8	40

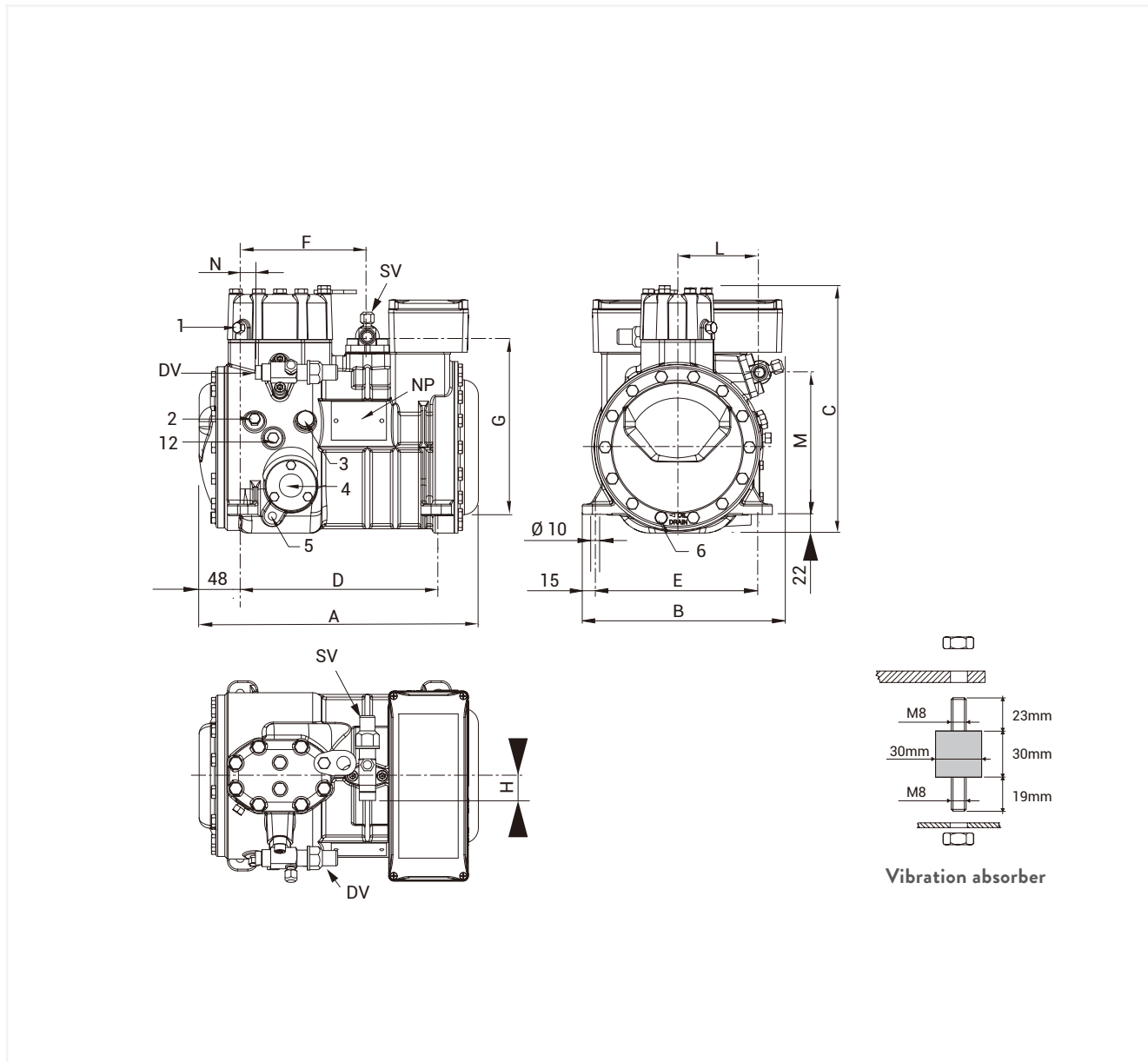

1	High pressure plug	1/8" NPT
2	Low pressure plug	1/8" NPT
3	Oil charge plug	1/4" GAS
4	Oil level sight glass	
5	Crankcase heater socket	
6	Oil drain plug	M8 x 22
12	Oil return plug	1/8" NPT
DV	Discharge valve	
SV	Suction valve	
NP	Nameplate	

## Dimensional drawing

### D Series

	Compressor					Valves position						Valves				Net Weight [Kg]
	Length	Width	Height	Base mounting		Suction			Discharge			Suction		Discharge		
	A	B	C	D	E	F	G	H	L	M	N	Ø		Ø		
	[mm]	[mm]	[mm]	[mm]	[mm]	[mm]	[mm]	[mm]	[mm]	[mm]	[mm]	[inch]	[mm]	[inch]	[mm]	
D2-11.1Y*	369	242	294	234	194	165	221	42	94	192	13	7/8"	22,2	5/8"	15,8	45
D2-13.1Y*	369	242	294	234	194	165	221	42	94	192	13	7/8"	22,2	5/8"	15,8	45
D3-13.1Y	374	242	317	234	194	165	225	53	94	192	13	1-1/8"	28,6	5/8"	15,8	49
D2-15.1Y*	369	242	294	234	194	165	221	42	94	192	13	7/8"	22,2	5/8"	15,8	45
D3-15.1	374	242	317	234	194	165	225	53	94	192	13	1-1/8"	28,6	5/8"	15,8	49
D3-16.1Y	374	242	317	234	194	165	225	53	94	192	13	1-1/8"	28,6	5/8"	15,8	49
D4-16.1Y	401	242	317	234	194	165	225	53	94	192	5	1-1/8"	28,6	3/4"	19,0	55
D3-18.1Y	374	242	317	234	194	165	225	53	94	192	13	1-1/8"	28,6	5/8"	15,8	55
D4-18.1Y	401	242	317	234	194	165	225	53	94	192	5	1-1/8"	28,6	3/4"	19,0	55
D3-19.1Y	374	242	317	234	194	165	225	53	94	192	13	1-1/8"	28,6	5/8"	15,8	49
D4-19.1Y	401	242	317	234	194	165	225	53	94	192	5	1-1/8"	28,6	3/4"	19,0	55

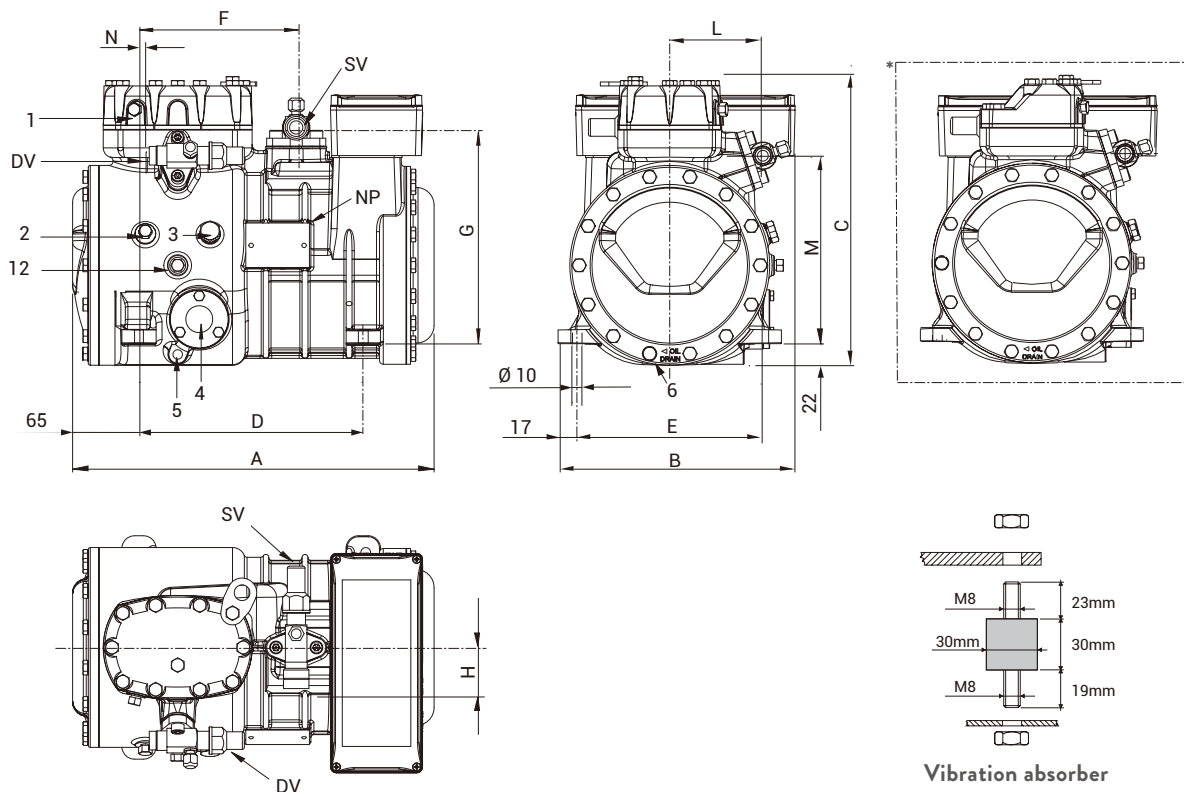

1	High pressure plug	1/8" NPT
2	Low pressure plug	1/8" NPT
3	Oil charge plug	1/4" GAS
4	Oil level sight glass	
5	Crankcase heater socket	
6	Oil drain plug	M8 x 22
12	Oil return plug	1/8" NPT
DV	Discharge valve	
SV	Suction valve	
NP	Nameplate	

## Dimensional drawing

### Q Series

	Compressor					Valves position						Valves				Net Weight [Kg]
	Length	Width	Height	Base mounting		Suction			Discharge			Suction		Discharge		
				A	B	C	D	E	F	G	H	L	M	N	Ø	
	[mm]	[mm]	[mm]	[mm]	[mm]	[mm]	[mm]	[mm]	[mm]	[mm]	[mm]	[mm]	[mm]	[mm]	[mm]	
Q4-20.1Y	449	286	325	312	246	203	258	53	123	239	12	1-1/8"	28,6	3/4"	19,0	74
Q4-21.1Y																
Q5-21.1Y	449	286	325	312	246	203	258	53	123	239	12	1-1/8"	28,6	3/4"	19,0	79
Q4-24.1Y																
Q5-24.1Y	449	286	325	312	246	203	258	53	123	239	17	1-1/8"	28,6	7/8"	22,2	79
Q4-25.1Y	449	286	325	312	246	203	258	53	123	239	17	1-1/8"	28,6	3/4"	19,0	77
Q5-25.1Y																
Q7-25.1Y	449	286	325	312	246	203	258	53	123	239	17	1-1/8"	28,6	7/8"	22,2	79
Q5-28.1Y	449	286	325	312	246	203	261	58	123	239	17	1-3/8"	35,0	7/8"	22,2	79
Q7-28.1Y																
Q5-33.1Y	449	286	328	312	246	203	261	58	123	239	28	1-3/8"	35,0	1-1/8"	28,6	79
Q7-33.1Y																
Q7-36.1Y	449	286	328	312	246	203	261	58	123	239	28	1-3/8"	35,0	1-3/8"	28,6	79

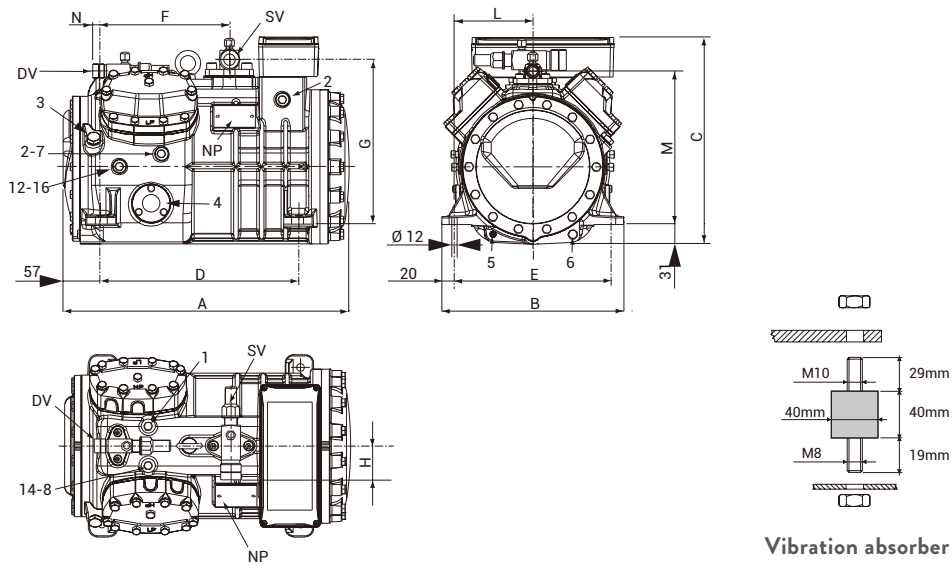

1	High pressure plug	1/8" NPT
2	Low pressure plug	1/8" NPT
3	Oil charge plug	1/4" GAS
4	Oil level sight glass	
5	Crankcase heater socket	
6	Oil drain plug	M8 x 22
7	Liquid injection valve plug	1/8" NPT
8	Liquid injection sensor plug	1/8" NPT
12	Oil return plug	1/8" NPT
14	Max discharge temperature sensor	1/8" NPT
16	Crankcase pressure plug	1/8" NPT
DV	Discharge valve	
SV	Suction valve	
NP	Nameplate	

## Dimensional drawing

### S Series

	Compressor					Valves position						Valves				Net Weight [Kg]
	Length	Width	Height	Base mounting		Suction			Discharge			Suction		Discharge		
	A	B	C	D	E	F	G	H	L	M	N	Ø		Ø		
	[mm]	[mm]	[mm]	[mm]	[mm]	[mm]	[mm]	[mm]	[mm]	[mm]	[mm]	[inch]	[mm]	[inch]	[mm]	
S5-33Y	550	405	405	292	266	147	115	58	133	298	23	1-3/8"	35,0	1-1/8"	28,6	115
S7-33Y	550	405	405	292	266	147	115	58	133	298	23	1-3/8"	35,0	1-1/8"	28,6	117
S8-42Y	550	405	405	292	266	147	115	58	133	298	23	1-3/8"	35,0	1-1/8"	28,6	117
S12-42Y	550	405	405	292	266	147	115	58	133	298	23	1-3/8"	35,0	1-1/8"	28,6	120
S10-52Y	550	405	405	292	266	147	115	58	133	298	23	1-3/8"	35,0	1-1/8"	28,6	120
S15-52Y	550	405	405	292	266	147	115	61	133	298	23	1-5/8"	42,0	1-1/8"	28,6	126
S15-56Y	550	405	405	292	266	147	115	61	133	298	23	1-5/8"	42,0	1-1/8"	28,6	130
S20-56Y	550	405	405	292	266	147	115	61	133	298	23	1-5/8"	42,0	1-1/8"	28,6	132

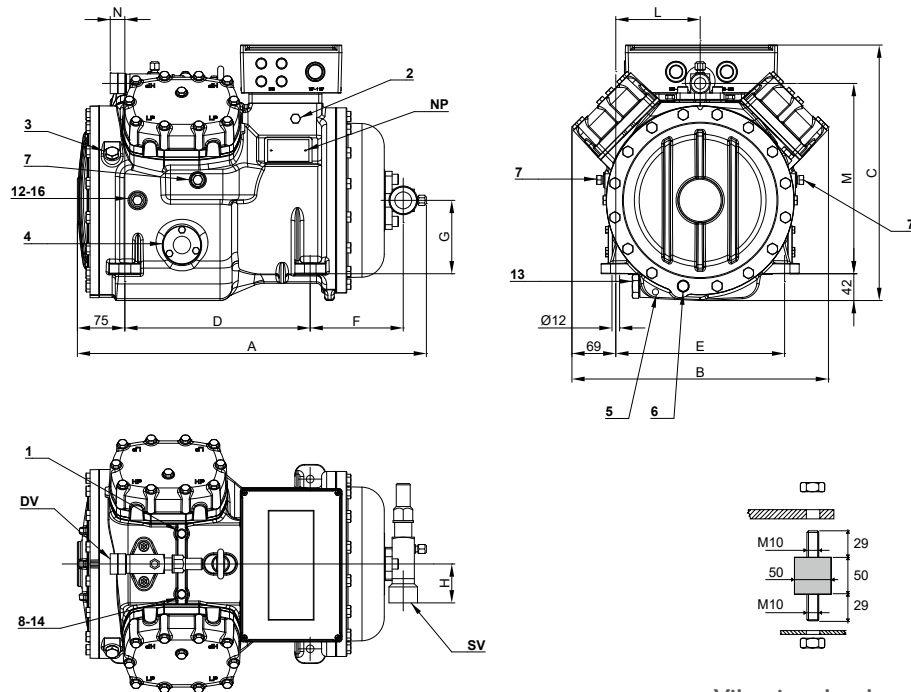

Vibration absorber

1	High pressure plug	1/8" NPT
2	Low pressure plug	1/8" NPT
3	Oil charge plug	1/4" GAS
4	Oil level sight glass	
5	Crankcase heater socket	
6	Oil drain plug	M10 x 30
7	Liquid injection valve plug	1/4" NPT
8	Liquid injection sensor plug	1/8" NPT
12	Oil return plug	1/4" NPT
13	Magnetic plug	1/2" GAS
14	Max discharge temperature sensor	1/8" NPT
16	Crankcase pressure plug	1/4" NPT
DV	Discharge valve	
SV	Suction valve	
NP	Nameplate	



## Dimensional drawing

### S Series

	Compressor					Valves position						Valves				Net Weight [Kg]
	Length	Width	Height	Base mounting		Suction			Discharge			Suction		Discharge		
	A	B	C	D	E	F	G	H	L	M	N	Ø		Ø		
	[mm]	[mm]	[mm]	[mm]	[mm]	[mm]	[mm]	[mm]	[mm]	[mm]	[mm]	[inch]	[mm]	[inch]	[mm]	
S20-63Y	625	405	401	292	266	216	115	69	133	298	23	1-5/8"	42,0	1-1/8"	28,6	137
S25-63Y	625	405	401	292	266	216	115	69	133	298	23	1-5/8"	42,0	1-1/8"	28,6	139

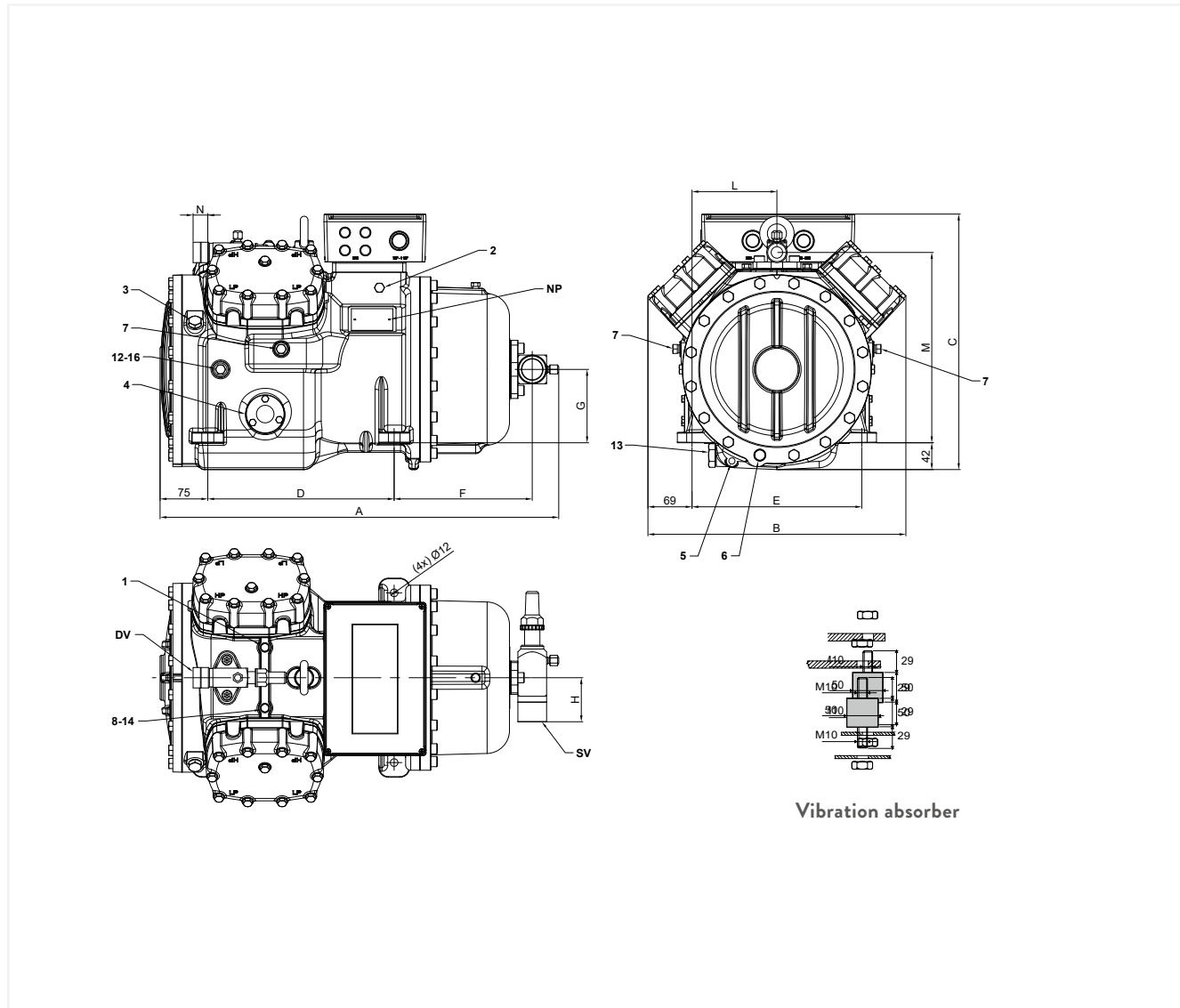

Vibration absorber

1	High pressure plug	1/8" NPT
2	Low pressure plug	1/8" NPT
3	Oil charge plug	1/4" GAS
4	Oil level sight glass	
5	Crankcase heater socket	
6	Oil drain plug	M10 x 30
7	Liquid injection valve plug	1/4" NPT
8	Liquid injection sensor plug	1/8" NPT
12	Oil return plug	1/4" NPT
13	Magnetic plug	1/2" GAS
14	Max discharge temperature sensor	1/8" NPT
16	Crankcase pressure plug	1/4" NPT
DV	Discharge valve	
SV	Suction valve	
NP	Nameplate	

## Dimensional drawing

### V Series

	Compressor					Valves position						Valves				Net Weight [Kg]
	Length	Width	Height	Base mounting		Suction			Discharge			Suction		Discharge		
				A	B	C	D	E	F	G	H	L	M	N	Ø	
	[mm]	[mm]	[mm]	[mm]	[mm]	[mm]	[mm]	[mm]	[mm]	[mm]	[mm]	[mm]	[inch]	[mm]	[inch]	
V15-59Y	672	460	463	381	305	120	367	95	152	352	43	1-5/8"	42,0	1-1/8"	28,6	170
V20-59Y	672	460	463	381	305	120	367	95	152	352	43	1-5/8"	42,0	1-1/8"	28,6	174
V15-71Y	672	460	463	381	305	120	367	95	152	352	43	1-5/8"	42,0	1-1/8"	28,6	170
V25-71Y	703	460	463	381	305	133	389	130	152	352	48	2-1/8"	54,0	1-1/8"	35,0	184
V20-84Y	672	460	463	381	305	120	367	95	152	352	43	1-5/8"	42,0	1-1/8"	28,6	180
V30-84Y	703	460	463	381	305	133	389	130	152	352	48	2-1/8"	54,0	1-3/8"	35,0	187
V25-93Y	703	460	463	381	305	133	389	130	152	352	48	2-1/8"	54,0	1-3/8"	35,0	190
V32-93Y	743	460	463	381	305	158	389	130	152	352	48	2-1/8"	54,0	1-3/8"	35,0	192
V25-103Y	703	460	463	381	305	133	389	130	152	352	48	2-1/8"	54,0	1-3/8"	35,0	190
V35-103Y	743	460	463	381	305	158	389	130	152	352	48	2-1/8"	54,0	1-3/8"	35,0	192
V30-112Y	743	460	463	381	305	158	389	130	152	352	48	2-1/8"	54,0	1-3/8"	35,0	190
V35-112Y	743	460	463	381	305	158	389	130	152	352	48	2-1/8"	54,0	1-3/8"	35,0	193
V30-123Y	743	460	463	381	305	158	389	130	152	352	48	2-1/8"	54,0	1-3/8"	35,0	190
V40-123Y	743	460	463	381	305	158	389	130	152	352	48	2-1/8"	54,0	1-3/8"	35,0	199

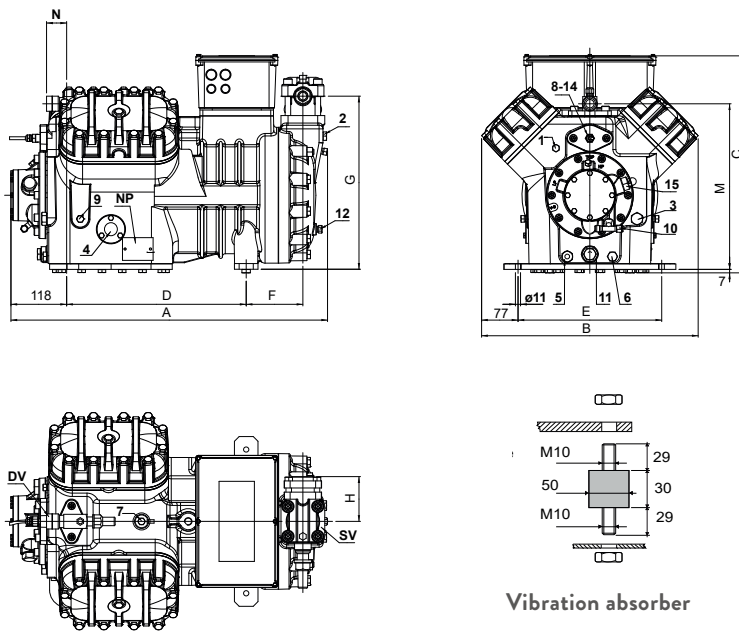

Vibration absorber

1	High pressure plug	1/8" NPT
2	Low pressure plug	1/4" NPT
3	Oil charge plug	3/8" GAS
4	Oil level sight glass	
5	Crankcase heater socket	
6	Oil drain plug	1/4" GAS
7	Liquid injection valve plug	1/4" NPT
8	Liquid injection sensor plug	1/8" NPT
9	Oil pressure switch connection (LP)	1/4" NPT
10	Oil pressure switch connection (HP)	1/4" SAE
11	Oil filter	3/8" GAS
12	Oil return plug	1/4" NPT
14	Max discharge temperature sensor	1/8" NPT
15	Electronic oil pressure switch connection	3/4" UNF
DV	Discharge valve	
SV	Suction valve	
NP	Nameplate	

## Dimensional drawing

### Z Series

	Compressor					Valves position						Valves				Net Weight [Kg]
	Length	Width	Height	Base mounting		Suction			Discharge			Suction		Discharge		
	A	B	C	D	E	F	G	H	L	M	N	Ø	Ø			
	[mm]	[mm]	[mm]	[mm]	[mm]	[mm]	[mm]	[mm]	[mm]	[mm]	[mm]	[inch]	[mm]	[inch]	[mm]	
Z25-106Y	765	509	457	381	305	155	386	130	123	274	42	2-1/8"	54,0	1-3/8"	35,0	220
Z35-106Y	806	509	457	381	305	180	386	130	123	274	42	2-1/8"	54,0	1-3/8"	35,0	223

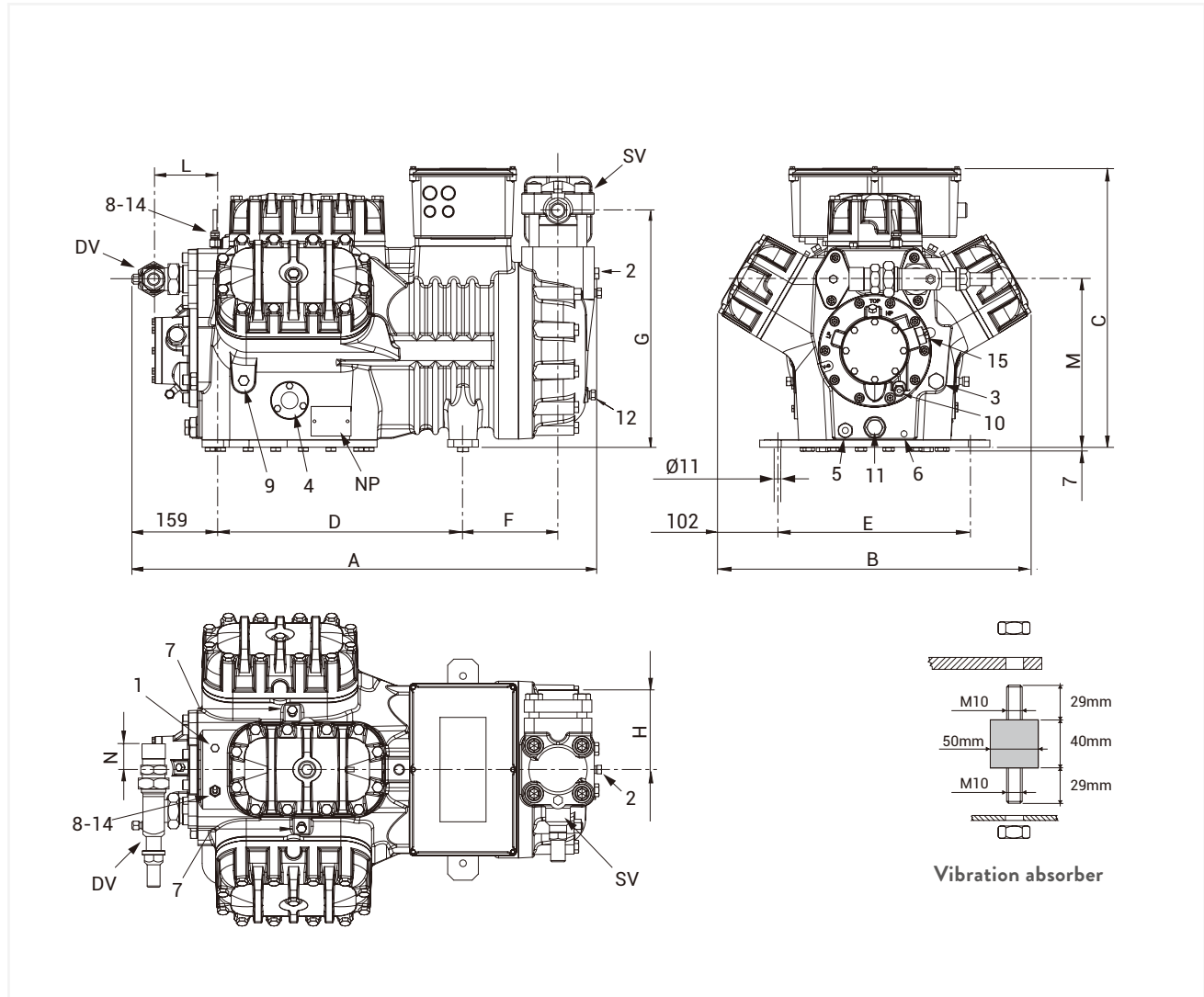

1	High pressure plug	1/8" NPT
2	Low pressure plug	1/4" NPT
3	Oil charge plug	3/8" GAS
4	Oil level sight glass	
5	Crankcase heater socket	
6	Oil drain plug	1/4" GAS
7	Liquid injection valve plug	1/8" NPT
8	Liquid injection sensor plug	1/8" NPT
9	Oil pressure switch connection (LP)	1/4" NPT
10	Oil pressure switch connection (HP)	1/4" SAE
11	Oil filter	3/8" GAS
12	Oil return plug	1/4" NPT
14	Max discharge temperature sensor	1/8" NPT
15	Electronic oil pressure switch connection	3/4" UNF
DV	Discharge valve	
SV	Suction valve	
NP	Nameplate	

# Dimensional drawing

## Z Series

	Compressor					Valves position						Valves				Net Weight [Kg]
	Length	Width	Height	Base mounting		Suction			Discharge			Suction		Discharge		
	A	B	C	D	E	F	G	H	L	M	N	Ø		Ø		
	[mm]	[mm]	[mm]	[mm]	[mm]	[mm]	[mm]	[mm]	[mm]	[mm]	[mm]	[inch]	[mm]	[inch]	[mm]	
Z30-126Y	765	509	536	381	305	155	433	130	123	321	42	2-1/8"	54,0	1-3/8"	35,0	229
Z40-126Y	806	509	536	381	305	180	433	130	123	321	42	2-5/8"	67,0	1-3/8"	42,0	240

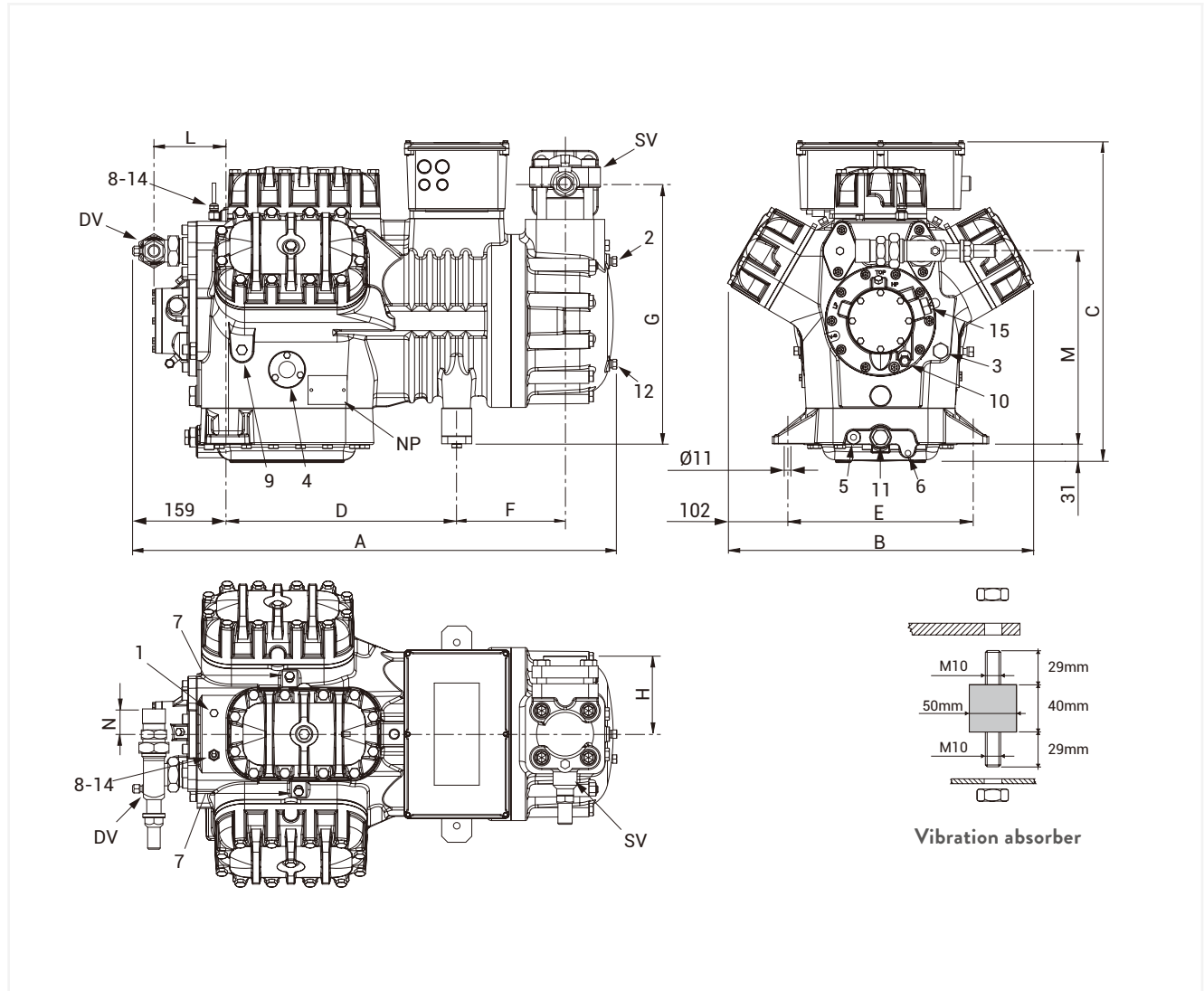

36

1	High pressure plug	1/8" NPT
2	Low pressure plug	1/4" NPT
3	Oil charge plug	3/8" GAS
4	Oil level sight glass	
5	Crankcase heater socket	
6	Oil drain plug	1/4" GAS
7	Liquid injection valve plug	1/8" NPT
8	Liquid injection sensor plug	1/8" NPT
9	Oil pressure switch connection (LP)	1/4" NPT
10	Oil pressure switch connection (HP)	1/4" SAE
11	Oil filter	3/8" GAS
12	Oil return plug	1/4" NPT
14	Max discharge temperature sensor	1/8" NPT
15	Electronic oil pressure switch connection	3/4" UNF
DV	Discharge valve	
SV	Suction valve	
NP	Nameplate	



## Dimensional drawing

### W Series

	Compressor					Valves position						Valves				Net Weight [Kg]
	Length	Width	Height	Base mounting		Suction			Discharge			Suction		Discharge		
	A	B	C	D	E	F	G	H	L	M	N	Ø		Ø		
	[mm]	[mm]	[mm]	[mm]	[mm]	[mm]	[mm]	[mm]	[mm]	[mm]	[mm]	[inch]	[mm]	[inch]	[mm]	
W40-168Y	838	511	588	458	305	158	486	160	95	358	95	2-5/8"	67,0	1-5/8"	42,0	299
W50-168Y	838	511	588	458	305	158	486	160	95	358	95	3-1/8"	79,4	1-5/8"	42,0	305
W50-187Y	838	511	588	458	305	158	486	160	95	358	95	3-1/8"	79,4	1-5/8"	42,0	311
W60-187Y	838	511	588	458	305	158	486	160	95	358	95	3-1/8"	79,4	1-5/8"	42,0	315
W60-206Y	838	511	588	458	305	158	486	160	95	358	95	3-1/8"	79,4	2-1/8"	54,0	320
W70-206Y	864	511	588	458	305	190	486	160	95	358	162	3-1/8"	79,4	2-1/8"	54,0	328
W70-228Y																
W75-228Y																
W75-240Y	864	519	588	458	305	190	486	160	95	358	162	3-1/8"	79,4	2-1/8"	54,0	328
W80-240Y																

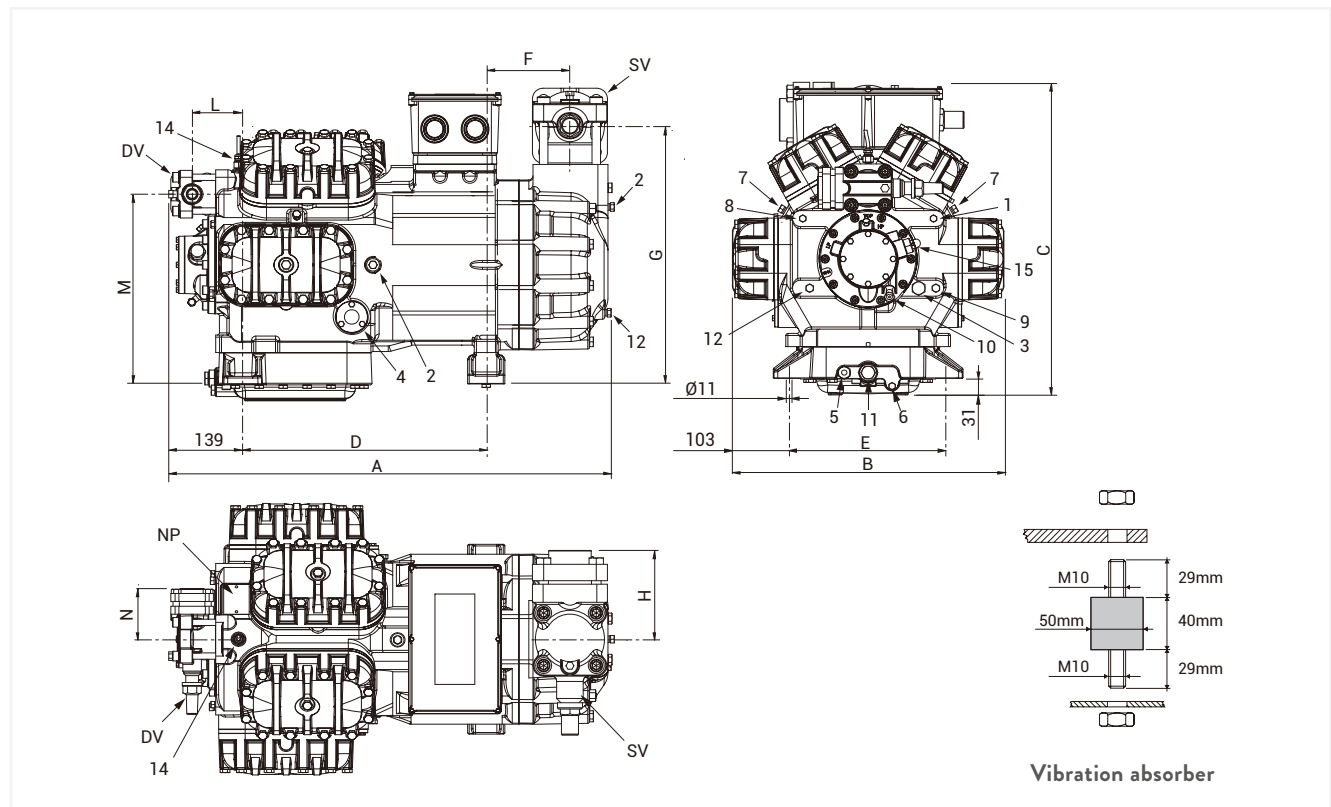

1	High pressure plug	1/8" NPT
2	Low pressure plug	1/4" NPT
3	Oil charge plug	3/8" GAS
4	Oil level sight glass	
5	Crankcase heater socket	
6	Oil drain plug	1/4" GAS
7	Liquid injection valve plug	1/8" NPT
8	Liquid injection sensor plug	1/8" NPT
9	Oil pressure switch connection (LP)	1/4" NPT
10	Oil pressure switch connection (HP)	1/4" SAE
11	Oil filter	3/8" GAS
12	Oil return plug	1/4" NPT
14	Max discharge temperature sensor	1/8" NPT
15	Electronic oil pressure switch connection	3/4" UNF
DV	Discharge valve	
SV	Suction valve	
NP	Nameplate	



# CONTACT & SUBSIDIARIES







## HEADQUARTERS & PRODUCTION PLANT

### FRASCOLD SPA - ITALY, MILAN

Via B. Melzi 105, 20027 Rescaldina (MI) Italy  
Tel. +39 0331 742201 - Fax +39 0331 576102  
frascold@frascold.it - www.frascold.it

## SALES OFFICE

### FRASCOLD CHINA

Frascold Refrigeration Co. Ltd  
Room 612, 6th Floor,  
Jinqiao Life Hub, No.3611  
Zhangyang Road, New Pudong District,  
Shanghai, CHINA  
Ph. +86 021 58650192 / 58650180  
Fax +86 021 58650180 - frascold.china@frascold.net

### FRASCOLD INDIA PVT LTD

Frascold India Pvt Ltd.  
A1/2/14/15, Gallops Industrial Park,  
NH-8A, Sarkhej-Bavla Road, Rajoda,  
Ahmedabad 382220 Gujarat. INDIA  
Ph: +91 2717 685858,  
sales@frascoldindia.com - www.frascoldindia.com

### FRASCOLD USA

5343 Bowden Road, Suite 2  
Jacksonville, FL 32216 - Ph. +1 (855) 547 5600 Office  
info@frascoldusa.com - www.frascoldusa.com

### FRASCOLD VIETNAM CO., LTD.

Room No. 701, Fl. 7, Cobi Tower I, 5 Hoang Van Thai,  
District 7, Ho Chi Minh  
Phone No: 028 54117375

## CDU ASSEMBLY PLANT

### FRASCOLD TAIZHOU

Frascold Refrigeration Equipment (Taizhou) Co. ,Ltd.  
Building 10 of phase three of the standard factory, Free  
Trade Zone. No. 88, Weichuang road, Taizhou city of  
Jiangsu province, China. 225300.  
Ph: +86 523 86888317  
www.frascold.net

Frascold India Pvt Ltd.  
A172715716, Gallops Industrial Park,  
NH-8A, Sarkhej-Bavla Rd, Rajoda,  
Ahmedabad, Gujarat 382220

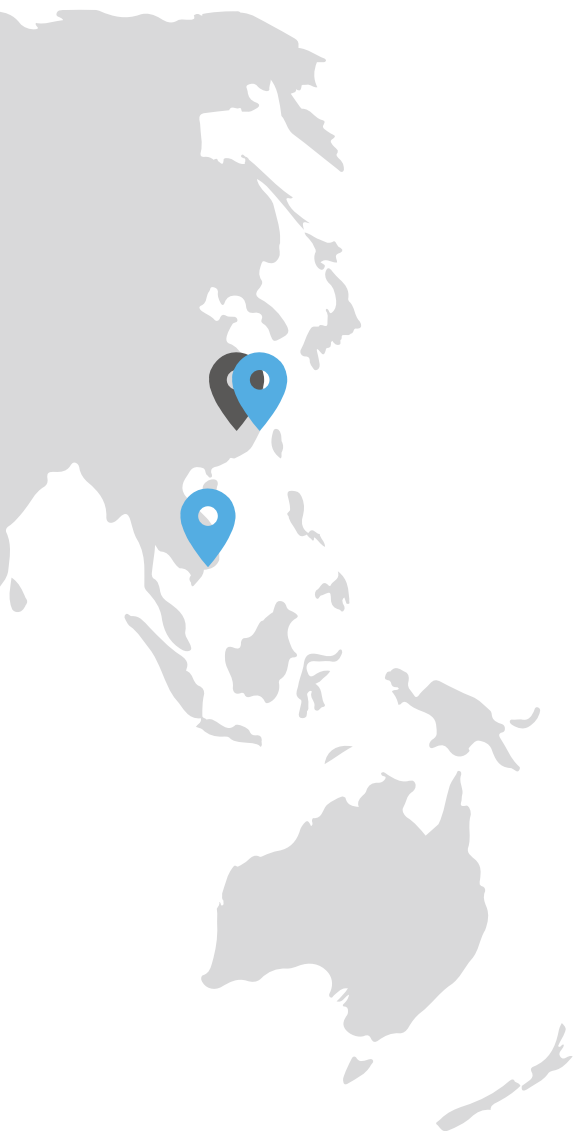

**FRASCOLD SPA**



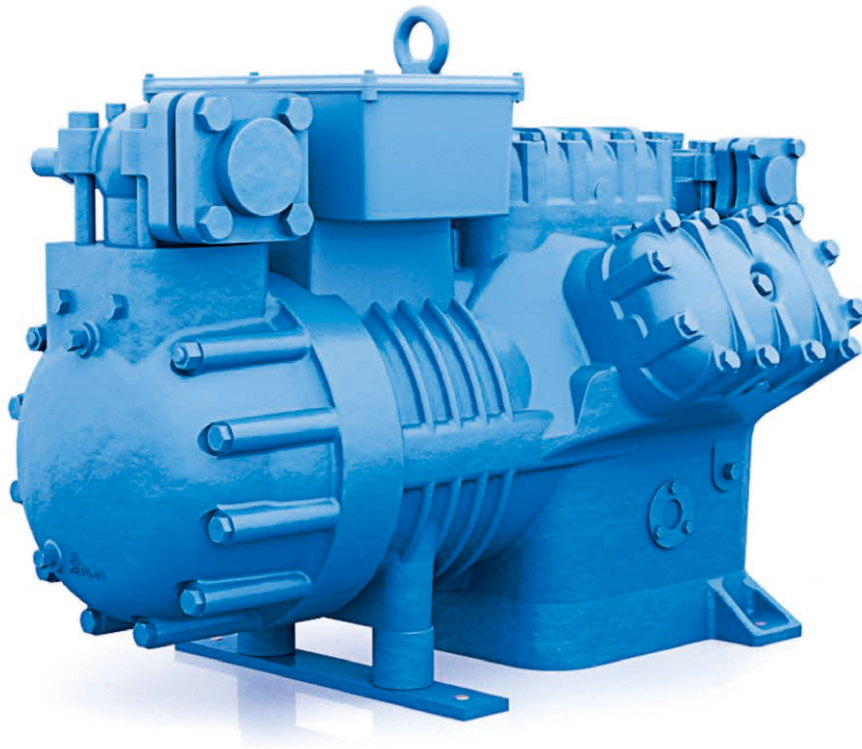

**FRASCOLD SPA**